

Instructions

95-8526

Infrared Hydrocarbon Gas Detector
PointWatch Eclipse®
Model PIRECL



Table of Contents

APPLICATION	1	OPERATION.....	20
		Factory Default Settings.....	20
OPERATION OVERVIEW.....	1	Operating Modes	20
Theory of Operation.....	1	4-20 ma Current Loop Output	20
Detectable Gases.....	2	Fault Indication.....	21
Outputs	2		
Data Logging Capability.....	2	STARTUP	22
Optional Third Party Addressable Modules	2	PIRECL Start-up/Commissioning Checklists	22
SPECIFICATIONS	3	CALIBRATION	23
		Calibration Overview	23
IMPORTANT SAFETY NOTES.....	7	Additional Calibration Notes.....	23
		Calibration Initiation	24
INSTALLATION	8	Detailed Calibration Procedure using Magnetic	
Identification of Flammable Vapor(s) to be		Switch	24
Detected	8	Time Out	25
Identification of Detector Mounting Locations	8	Calibration Abort	25
Physical Installation Requirements	8		
24 Vdc Power Supply Requirements	9	MAINTENANCE	26
Wiring Cable Requirements	9	Routine Inspection	26
Power Wiring Size and Maximum Length.....	9	Weather Baffle Cleaning	26
Optional Relays	10	Optics Cleaning	26
Wiring Procedure	10	O-Ring	26
Remote Calibration Wiring	10	Protective Caps and Covers.....	26
DESCRIPTION	16	TROUBLESHOOTING	27
Internal Magnetic Switch	16		
HART Communication	16	DEVICE REPAIR AND RETURN	27
Multicolor LED	17		
Weather Baffle Assembly	17	ORDERING INFORMATION	28
Clock	17	PointWatch Eclipse Detector	28
History Logs	17	Calibration Equipment	28
Remote Calibration Option.....	18	Spare Parts	28
Special Applications.....	18	Assistance	28
		APPENDIX A — HART COMMUNICATION.....	A-1
		APPENDIX B — MODBUS COMMUNICATION	B-1
		APPENDIX C — E Q PREMIER MODEL	C-1
		APPENDIX D — DETECTION OF OTHER GASES	D-1
		APPENDIX E — WARRANTY.....	E-1
		APPENDIX F — CONTROL DRAWING.....	F-1

Infrared Hydrocarbon Gas Detector

PointWatch Eclipse®

Model PIRECL

IMPORTANT

Be sure to read and understand the entire instruction manual before installing or operating the gas detection system. This product is intended to provide early warning of the presence of a flammable or explosive gas mixture. Proper device installation, operation, and maintenance is required to ensure safe and effective operation. If this equipment is used in a manner not specified in this manual, safety protection may be impaired.



APPLICATION

The Pointwatch Eclipse® Model PIRECL is a diffusion-based, point-type infrared gas detector that provides continuous monitoring of combustible hydrocarbon gas concentrations in the range of 0 to 100% LFL.

Three basic configurations are available:

- 4-20 mA output with HART communication protocol and RS-485 MODBUS communications.
- 4-20 mA output with HART communication protocol and RS-485 MODBUS communications, with two alarm relays and one fault relay.
- Eagle Quantum Premier (EQP) compatible version (no analog or relay outputs).

All units are powered from 24 volts DC, and are furnished with an onboard "status indication" LED, an internal magnetic calibration switch and an external calibration line for use with the optional PIRTB remote calibration termination box.

The Pointwatch Eclipse is ideal for use in harsh outdoor environments and is certified for use in Class I, Division 1, and Zone 1 hazardous areas. It can be used as a stand-alone detector, or as part of a larger facility protection system using other Det-Tronics equipment such as the FlexVu® UD10 Universal Display Unit, the U9500H Infiniti Transmitter, the R8471H Controller, or the Eagle Quantum Premier Fire and Gas Detection/Releasing System.

OPERATION OVERVIEW

THEORY OF OPERATION

Flammable hydrocarbon gases diffuse through the weather baffle assembly into the internal measurement chamber, which is illuminated by an infrared (IR) source. As the IR passes through the gas within the chamber, certain IR wavelengths are absorbed by the gas, while other IR wavelengths are not. The amount of IR absorption is determined by the concentration of the hydrocarbon gas. A pair of optical detectors and associated electronics measure the absorption. The change in intensity of the absorbed light (active signal) is measured relative to the intensity of light at a non-absorbed wavelength (reference signal). See Figure 1. The microprocessor computes the gas concentration and converts the value into a 4 to 20 milliampere current output or digital process variable signal, which is then communicated to external control and annunciation systems.

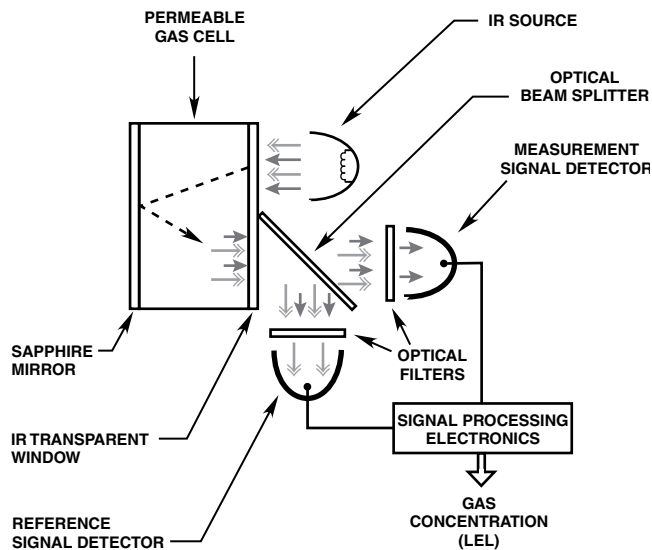

Figure 1—Measurement Scheme for Infrared Gas Detector

DETECTABLE GASES

Eclipse is capable of detecting many hydrocarbon gases and vapors. Field selectable standard settings are provided for methane, ethane, propane, butane, ethylene, and propylene. Gas type and other operational parameters are selected via digital communications. Factory default setting is methane.

OUTPUTS

Standard

The standard version provides an isolated/non-isolated 4-20 mA current loop for connection to analog input devices.

Optional Relays

An optional relay output board providing two programmable alarm relay outputs and one fault relay output can be factory installed with the standard version. All relays are sealed and provide form C (NO/NC) contacts. The high and low alarm relay settings are programmable and can be set for latching or non-latching operation. The low alarm cannot be set above the high alarm threshold. Alarm configuration can be done with the HART or MODBUS interface. The onboard multicolor LED indicates a LOW alarm condition via a flashing red color, and a HIGH alarm condition via a steady red color. The Eclipse internal magnetic switch or HART Field Communicator can be used to reset latched alarms. A short-duration magnetic switch activation of 1 second will reset latched alarms. Holding the magnetic switch

closed for 2 seconds will start the calibration sequence. The external calibration line will not reset latched alarm relays.

When the optional relay output board is specified, the PIRECL's approval rating is Ex d only.

NOTE

Refer to "Alarm Relays" in the Specifications section of this manual for important information regarding alarm relays.

EQP Version

The Eagle Quantum Premier model provides proprietary digital signals that are compatible with the EQ Premier network (LON) only. No analog 4-20 mA or RS-485 MODBUS signal outputs are provided. The optional onboard HART communication port is operational, but is not recommended for programming use. All programming of the EQP PIRECL detector should be accomplished using the S3 point configuration software. Refer to the EQP appendix within this manual for additional information.

DATA LOGGING CAPABILITY

Non-volatile memory is provided to save the 10 most recent calibrations, alarm/fault events, and minimum/maximum operating temperature history. An hour meter (running operational hours since startup) is provided to record operating service time and to give an indication of the relative time between events. This information is accessible using HART, MODBUS communication, or EQP system software.

OPTIONAL THIRD PARTY ADDRESSABLE MODULES

The PIRECL is electrically compatible with third party addressable modules, provided the module fits within the PIRECL wiring compartment. Whenever a third party addressable module is installed, the PIRECL's Ex e rating and FM Approval are void, and only the Ex d rating is valid. Installation of a third party addressable module requires a specially labeled PIRECL model to ensure valid product approvals.

SPECIFICATIONS

INPUT VOLTAGE (All Models)—

24 Vdc nominal. Operating range is 18 to 32 Vdc.
Ripple cannot exceed 0.5 volts P-P.

POWER CONSUMPTION (All Models)—

Detector without Relays

4.0 watts nominal @ 24 Vdc
7.5 watts peak @ 24 Vdc
10 watts peak @ 32 Vdc.

Detector with Relays

5.5 watts nominal @ 24 Vdc
8.0 watts peak @ 24 Vdc
10.0 watts peak @ 32 Vdc.

GAS DETECTION RANGE—

0 to 100% LFL standard. Other ranges are configurable (down to 20% full scale).

DETECTABLE GASES—

Most flammable hydrocarbon vapors are detectable. Standard gases include methane, ethane, ethylene, propane, butane and propylene. Methane gas detection is the factory default gas type setting. Detector programming and setup for detection of non-standard gases is accomplished using HART, MODBUS or EQP system software.

DETECTOR CONFIGURATION OPTIONS—

A significant number of PIRECL configuration parameters are field programmable including gas type, measurement range, alarm setpoints, tag number, special notations, password protection, etc. Details are provided within the HART Communication Appendix within this document. Three PIRECL field configuration programming methods are supported:

- HART Communication
- EQP System S3 Software
- RS-485 MODBUS Communication

THIRD PARTY ADDRESSABLE MODULE (Optional)—

Input Voltage: 30 Vdc.
Input Current: 30 mA.

SHORT CIRCUIT CURRENT

(Non-Relay Output Versions Only)—

Power Supply Short Circuit Current (Isc): 5.4 amperes*
Short Circuit Current on Fused Line: 3.1 amperes*
Power Supply Max Voltage: Um = 250V**

* For installations in accordance with Increased Safety wiring practices.

** For intrinsically safe HART communication port.

WARM-UP TIME (ALL MODELS)—

Device enters normal mode after two minutes upon cold power-up. One hour warm-up time is recommended for optimum performance. Signal output level during warm-up is programmable.

CURRENT OUTPUT (Standard Models Only)—

Linear 4-20 mA (current source/sink, isolated/non-isolated) rated at 600 ohms maximum loop resistance @ 24 Vdc operating voltage.

VISUAL STATUS INDICATOR (All Models)—

Tri-color LED:

Red = Low alarm, high alarm, or calibration.
See Table 1 for Details.

Green = Power on / OK

Yellow = Fault or warm-up.

RELAY OUTPUTS (Optional)—

(Available on Ex d approved models only, not available on Eagle Premier model).

ALARM RELAYS—

Low and High

Form C Type (NO/NC).

De-Energized during Normal mode, Energized on Alarm.

Contact Rating: 5 amperes at 30 Vdc.

Programmable for Latching or Non-Latching Operation.

Setpoint Range (both): 5-60% LFL.

Note: Low alarm range for EQP model is 5-40% LFL.

Factory Default Settings:

Low: 20% LFL – Non-latching

High: 50% LFL – Non-latching

Alarm relay programming can be accomplished using HART or MODBUS.

CAUTION

*When the PIRECL Gas Detector is used in conjunction with an appropriate certified Control Unit and configured for a non-latching high alarm, the control unit must **always** latch and require a deliberate manual action to clear a high gas alarm. When used as a stand alone device, the high alarm must always be programmed for latching operation.*

FAULT RELAY—

Form C Type (NO/NC). Energized during Normal mode, De-Energized on Fault or loss of power.

Contact Rating: 5 amperes at 30 Vdc.

Non-Latching Operation only — not programmable.

DIGITAL OUTPUT (Optional)—

Digital communication, transformer isolated (78.5 kbps).

CALIBRATION—

All units are methane-calibrated at the factory. Field calibration may not be required for methane detection applications. Field selectable standard gas settings are provided for methane, ethane, propane, butane, ethylene, and propylene.

Field programming and full calibration is typically required for detection of vapors other than methane. Refer to the “Calibration” section of this manual for details.

Routine calibration of the PIRECL after completion of initial commissioning is supported, but not absolutely required. Generally, an annual gas bump test or full calibration will ensure proper sensitivity and response.

NOTE

Frequent visual inspections of the PIRECL are recommended to confirm that there are no external impediments to proper detection capability.

Four methods of initiating Calibration are supported:

- On-Board magnetic reed switch
- HART communication
- Remote calibration line for remote switch
- MODBUS communication

RESPONSE TIME (Average in Seconds, with Weather Protection Baffle Installed, and 100% LFL Applied)—

	T50	T60	T90
Without Hydrophobic Filter:	3.7	4.0	6.4
With Hydrophobic Filter:	4.4	4.8	8.2

NOTE

Add 1 second to response time for EQP compatible models.

TEMPERATURE RANGE—

Operating: -40°C to +75°C (-40°F to +167°F)
Storage: -55°C to +85°C (-67°F to +185°F)

HUMIDITY—

0 to 99% relative humidity (Det-Tronics verified).
5 to 95% relative humidity (FM/CSA/DEMKO verified).

VIBRATION—

PIRECL successfully passes Sinusoidal Vibration Testing in accordance with MIL-STD-810C, Method 514.2, Paragraph 4.5.1.3, Figure 514.2-7 Curve AW, and C22.2 No. 152-M1984, and also DET NORSE VERITAS Certification Notes – No. 2.4 dated May 1995.

ACCURACY—

±3% LFL from 0 to 50% LFL, ±5% LFL from 51 to 100% LFL (at room ambient temperature, +23°C).

SELF-DIAGNOSTIC TEST—

Fail-Safe operation ensured by performing all critical tests once per second.

INGRESS PROTECTION—

IP66/IP67 (DEMKO Verified).

ELECTRO-MAGNETIC COMPATIBILITY—

EMC Directive 2004/108/EC
EN61000-6-4 (Emissions)
EN61000-6-2 (Immunity)
EN50270 (EMC - electrical apparatus for the detection of combustible gas).

NOTE

Shielded cable is required.

FM Approvals: Product operates properly with 5 watt walkie talkie keyed at 1 meter.

DNV: Relevant tests according to “Standard for Certification No. 2.4”.

DETECTOR HOUSING MATERIAL—

316 stainless steel (CF8M).

CONDUIT ENTRY OPTIONS—

Two entries, 3/4 inch NPT or 25 mm.

HART COMMUNICATION PORT (optional)—

Intrinsically safe. For live maintenance, follow Control Drawing 007283-001 in appendix F.

OPTICS PROTECTION—

Three-layer weather baffle assembly is UV-resistant, static-dissipating black Polythalamide plastic. The standard weather baffle version recommended for most outdoor and indoor applications includes internal hydrophobic filter. Heated optics feature minimizes condensation to ensure reliable operation through temperature extremes.

WIRING—

Field wiring screw terminals are UL/CSA rated for up to 14 AWG wire, and are DIN/VDE rated for 2.5 mm² wire. Screw terminal required torque range is 3.5–4.4 in.-lbs. (0.4-0.5 N·m).

ELECTRICAL SAFETY CLASSIFICATION—

Installation Category (Overvoltage Category) II & Pollution Degree 2 per ANSI/ISA-S82.02.01, EN 61010-1 & IEC 61010-1.

CERTIFICATIONS—

FM & CSA:

Class I, Div. 1, Groups B, C & D (T4) with intrinsically safe output for HART communication in accordance with control drawing 007283-001.
Class I, Div. 2, Groups A, B, C & D (T4). Performance verified to Methane in accordance with FM 6310/6320, ANSI/ISA 12.13.01, and CSA C22.2 No. 152. Tamb = -40°C to +75°C.
Acidic atmospheres excluded.
Conduit seal not required.



NOTES

Approval of the Model PIRECL does not include or imply approval of the apparatus to which the detector may be connected and which processes the electronic signal for eventual end use. In order to maintain an approved system, the apparatus to which the detector is connected must also be approved.

This Approval does not include or imply Approval of the communications protocol or functions provided by the software of this instrument or of the communications apparatus or software connected to this instrument.

ATEX:

CE 0539 II 2 G
Ex de IIC T4-T5 Gb
-- OR --
Ex de [ib] IIC T4-T5 Gb
(with HART communication port)
DEMKO 01 ATEX 129485X.
(Performance verified to Methane in accordance with EN 60079-29-1).
T5 (Tamb -50°C to +40°C)
T4 (Tamb -50°C to +75°C)
IP66/IP67.
-- OR --
CE 0539 II 2 G
Ex d IIC T4-T5 Gb
-- OR --
Ex d [ib] IIC T4-T5 Gb
(with HART communication port)
DEMKO 01 ATEX 129485X.
(Performance verified to Methane in accordance with EN 60079-29-1).
T5 (Tamb -55°C to +40°C)
T4 (Tamb -55°C to +75°C)
IP66/IP67.
HART Communication Port:
U_o = 4.0V C_o = 20µF
I_o = 100mA L_o = 500µH



Performance testing to EN60079-29-1:

The measuring function of the Infrared Gas Detector model PIRECL for explosion protection, according to Annex II clause 1.5.5, 1.5.6 and 1.5.7 of the Directive 94/9/EC is, for methane, covered in this EC-Type Examination Certificate in the following configurations:

1. PIRECL Infrared Gas Detector (LON Model) tested in combination with the EQP System Controller Model EQ3XXX.
2. PIRECL Infrared Gas Detector tested in combination with the Model PIRTB, PointWatch Termination Box.
3. PIRECL Infrared Gas Detector tested in combination with the Model CTB Calibration Termination Box.
4. PIRECL Infrared Gas Detector tested as a stand-alone gas detector.

ATEX Special Conditions for Safe Use ('X'):

- The Infrared Gas Detector model PIRECL shall be installed in places where there is a low risk of mechanical damage.
- The field wiring terminal connections are certified for a single wire in size from 0.2 to 2.5 mm², (or two conductors with same cross section 0.2 to 0.75 mm²). The screws must be tightened down with a torque 0.4 to 0.5 Nm.
- The metal housing of the model PIRECL Infrared Hydrocarbon Gas Detector must be electrically connected to earth ground.
- The intrinsically safe output on the HART Communicator Port is internally connected to earth ground.
- The Infrared Gas Detector model PIRECL has an ambient temperature rating for performance of -55°C to +75 °C.
- Alarm output latching requirement: High alarm outputs must be configured as latching, either as part of the alarm operation of the gas detector itself (in stand-alone applications), or as a function of the "high alarm" indication within the controller that is directly connected to the gas detector (for remote applications).

Additional Safety Notes:

- The following warning is on the product:
Warning: Do not open when an explosive gas atmosphere may be present.
For ambient temperature above 60°C use field wiring suitable for maximum ambient temperature. For temperature below –10°C use suitable field wiring for the lowest temperature.
- The ambient temperature range is limited to –55°C to +75°C (for Ex d version) or –50°C to +75°C (for Ex de version).
- Cable, bushings and the conduit entries shall be of a type already certified according to relevant ATEX standard, so the protection principle employed will not be impaired.
- Unused conduit entries shall be closed using stop plugs certified for the conditions of use (IP66/IP67 minimum). The stop plugs should be removable only with the aid of a tool.
- The terminal compartment for Eclipse without relays is designed for either an increased safety “e” termination or a flameproof “d” termination of the supply cable. If a flameproof connection is chosen, then an ATEX certified cable entry device certified to EN60079 must be used. The Eclipse with relays requires Ex d cable entry devices only.

EN Standards: EN 50270: 2006
EN 50271: 2002
EN 60079-0: 2009
EN 60079-1: 2007
EN 60079-7: 2007
EN 60079-11: 2007
EN 60079-29-1: 2007
EN 60529: 1991+ A1 2000

CE: Conforms to:
Low Voltage Directive: 2006/95/EC,
EMC Directive: 2004/108/EC,
ATEX Directive: 94/9/EC.

IEC: IECEx ULD 04.0002X
Ex de IIC T4-T5 Gb
-- OR --
Ex de [ib] IIC T4-T5 Gb
(with HART communication port)
T5 (Tamb –50°C to +40°C)
T4 (Tamb –50°C to +75°C)
IP66/IP67.
-- OR --
IECEX ULD 04.0002X
Ex d IIC T4-T5 Gb
-- OR --
Ex d [ib] IIC T4-T5 Gb
(with HART communication port)
T5 (Tamb –55°C to +40°C)
T4 (Tamb –55°C to +75°C)
IP66/IP67.
HART Communication Port:
Uo = 4.0V Co = 20µF
Io = 100mA Lo = 500µH

SIL: IEC 61508
Certified SIL 2 Capable.



For SIL models, refer to the Safety Reference Manual, form 95-8630.

IEC Conditions of Certification:

- The field wiring terminal connections are certified for a single wire in size from 0.2 to 2.5 mm², (or two conductors with same cross section 0.2 to 0.75 mm²). The screws must be tightened down with a torque 0.4 to 0.5 Nm.
- The metal housing of the Model PIRECL Gas Detector must be electrically connected to earth ground.
- The gas detector shall be protected against any impact greater than 4 joules.
- The intrinsically safe output on the HART Communicator Port is internally connected to frame.
- The power supply for the detector has to be a Safety Isolating transformer according to e.g. IEC61558. The rating of the power supply line fuse shall be less than 3.1 A.
- When connecting to a circuit using up to 1% of Co or Lo, then the C or L is limited to the Co and Lo listed above. If either the C or L is above 1% of Co or Lo, then C or L are each limited to 50% of the Co or Lo listed above.
- Um is restricted to 250 V, prospective short circuit current < 1500 A.

IEC Standards: IEC 60079-0: 2007
IEC 60079-1: 2007-04
IEC 60079-11: 2006
IEC 60079-7: 2006-07
IEC 60529, 2.1 Edition with Corr. 1
(2003-01 + 2 (2007-10))

WARNING

Always ensure that the detector/junction box hazardous (classified) location ratings are applicable for the intended use.

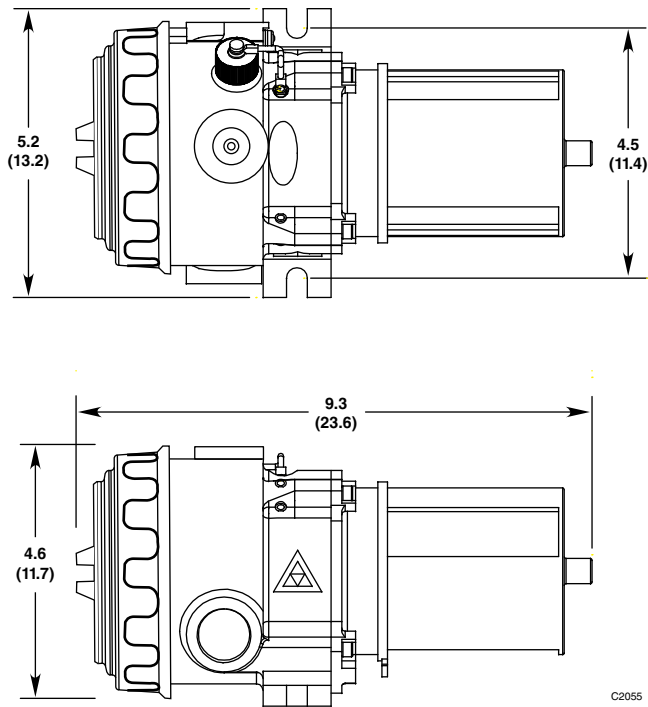

Figure 2—Dimensions of Eclipse Detector in Inches (Centimeters)

DIMENSIONS—
See Figure 2.

SHIPPING WEIGHT (Approximate)—
11.5 pounds (5.2 kg).

WARRANTY—
Five year limited warranty from date of manufacture.
See Appendix E for details.

IMPORTANT SAFETY NOTES

CAUTION

The wiring procedures in this manual are intended to ensure proper functioning of the device under normal conditions. However, because of the many variations in wiring codes and regulations, total compliance to these ordinances cannot be guaranteed. Be certain that all wiring complies with the NEC as well as all local ordinances. If in doubt, consult the authority having jurisdiction before wiring the system. Installation must be done by a properly trained person.

CAUTION

This product has been tested and approved for use in hazardous areas. However, it must be properly installed and used only under the conditions specified within this manual and the specific approval certificates. Any device modification, improper installation, or use in a faulty or incomplete configuration will render warranty and product certifications invalid.

CAUTION

The detector contains no user serviceable components. Service or repair should never be attempted by the user. Device repair should be performed only by the manufacturer or trained service personnel.

LIABILITIES

The manufacturer's warranty for this product is void, and all liability for proper function of the detector is irrevocably transferred to the owner or operator in the event that the device is serviced or repaired by personnel not employed or authorized by Detector Electronics Corporation, or if the device is used in a manner not conforming to its intended use.

CAUTION

Observe precautions for handling electrostatic sensitive devices.

NOTE

The PointWatch Eclipse is intended for detection of hydrocarbon vapors only. The device will not detect hydrogen gas.

INSTALLATION

Before installing the Pointwatch Eclipse, define the following application details:

IDENTIFICATION OF FLAMMABLE VAPOR(S) TO BE DETECTED

It is necessary to always identify the flammable vapor(s) of interest at the job site in order to determine the proper calibration gas setting for Pointwatch Eclipse. In addition, the fire hazard properties of the vapor, such as vapor density, flashpoint, and vapor pressure should be identified and used to assist in selecting the optimum detector mounting location within the area.

The detector must be installed per local installation practices. For IEC/ATEX hazardous areas, it may be acceptable to utilize Ex e wiring practices with the Eclipse (non-relay versions).

IDENTIFICATION OF DETECTOR MOUNTING LOCATIONS

Identification of the most likely leak sources and leak accumulation areas is typically the first step in identifying the best detector mounting locations. In addition, identification of air current / wind patterns within the protected area is useful in predicting gas leak dispersion behavior. This information should be used to identify optimum sensor installation points.

If the vapor of interest is lighter than air, place the sensor above the potential gas leak. Place the sensor close to the floor for gases that are heavier than air. For heavy vapors, typically locate Pointwatch Eclipse at 2-4 cm above grade elevation. Note that air currents may cause a gas that is slightly heavier than air to rise under some conditions. Heated gases may also exhibit the same phenomenon.

The most effective number and placement of detectors varies depending on the conditions at the job site. The individual designing the installation must often rely on experience and common sense to determine the detector quantity and best locations to adequately protect the area. Note that it is typically advantageous to locate detectors where they are accessible for maintenance, and also where the Eclipse status indication LED can easily be seen. Locations near excessive heat / vibration sources should be avoided if possible.

Final suitability of possible gas detector locations should be verified by a job site survey. Gas detector area of coverage is a subjective evaluation, and may require long-term empirical data to confirm effectiveness. A typical rule of thumb is that one detector can cover a 900 square foot area.

However, this rule of thumb is subject to change depending upon specific application properties and requirements.

NOTE

For additional information on determining the quantity and placement of gas detectors in a specific application, refer to the article titled "The Use of Combustible Detectors in Protecting Facilities from Flammable Hazards" contained in the Instrumentation, Systems and Automation Society (ISA) Transaction, Volume 20, Number 2.

PHYSICAL INSTALLATION REQUIREMENTS

Pointwatch Eclipse is provided with built-in mounting feet that will accept 3/8 inch (M8) diameter mounting bolts. Always ensure that the mounting surface is vibration-free and can suitably support the total weight of the Pointwatch Eclipse without assistance from electrical cabling or conduit system.

The detector must be installed per local installation practices. For IEC/ATEX hazardous areas, it may be acceptable to utilize Ex e wiring practices with the Eclipse.

Device Mounting Orientation

It is highly recommended that the Eclipse be installed in the horizontal position. The detector is not position-sensitive in terms of its ability to detect gas. However, the weather baffle assembly provides superior performance when the Eclipse is installed with the baffle in a horizontal position.

LED Visibility

Select a mounting orientation where the Pointwatch Eclipse status indication LED is visible to personnel within the area.

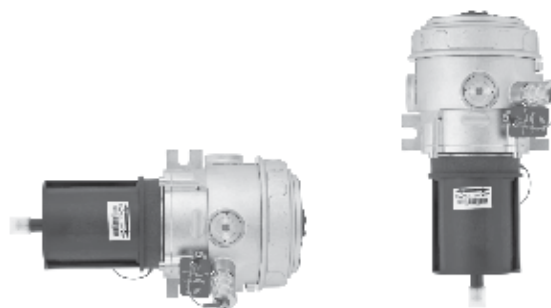

CORRECT

INCORRECT

Recommended Orientation of Eclipse Detector

Calibration Gas Port Cover

A protective cover for the calibration gas injection port is provided to ensure that contaminants are not accidentally introduced into the Eclipse optics. Ensure that this cover is properly installed over the port when calibration is not being performed.

NOTE

Failure to install the calibration gas port cover or the use of a damaged cover may result in nuisance faults and require cleaning the detector optics.

24 VDC POWER SUPPLY REQUIREMENTS

Calculate the total gas detection system power consumption rate in watts from cold start-up. Select a power supply with adequate capability for the calculated load. Ensure that the selected power supply provides regulated and filtered 24 Vdc output power for the entire system. If a back-up power system is required, a float-type battery charging system is recommended. If an existing source of 24 Vdc power is being utilized, verify that system requirements are met.

WIRING CABLE REQUIREMENTS

Always use proper cabling type and diameter for input power as well as output signal wiring. 14 to 18 AWG shielded stranded copper wire is recommended.

Always install a properly sized, master power fuse or breaker on the system power circuit.

NOTE

The use of shielded cable in conduit or shielded armored cable is required. In applications where the wiring is installed in conduit, dedicated conduit is recommended. Avoid low frequency, high voltage, and non-signaling conductors to prevent nuisance EMI problems.

CAUTION

The use of proper conduit installation techniques, breathers, glands, and seals is required to prevent water ingress and/or maintain the explosion-proof rating.

POWER WIRING SIZE AND MAXIMUM LENGTH

1. The Eclipse detector must receive 18 Vdc minimum to operate properly. 24 Vdc minimum is recommended.
2. Always determine voltage drops that will occur to ensure that 24 Vdc is delivered to the Eclipse.
3. Normally, nothing smaller than 18 AWG (0.75 mm²) is recommended by Det-Tronics for Eclipse power cabling.

Wire size requirements are dependent upon power supply voltage and wire length.

The maximum distance between the Eclipse detector and its power supply is determined by the maximum allowable voltage drop for the power wiring loop. If the voltage drop is exceeded, the device will not operate. To determine the maximum power loop voltage drop, subtract the minimum operating voltage for the device (18 Vdc) from the minimum output voltage of the power supply.

Maximum Power Loop
Voltage Drop =

Power Supply Voltage
Minus
Minimum Operating Voltage

To determine the actual maximum wire length:

1. Divide the maximum allowable voltage drop by the maximum current draw of the Eclipse (0.31 A),
2. Divide by the resistance of the wire (ohms/foot value available in wire manufacturer's specification data sheet),
3. Divide by 2.

Maximum Wire Length =

Maximum Voltage Drop
÷
Maximum Current
÷
Wire Resistance in Ohms/ Foot
÷
2

For example: Consider an installation using 18 AWG wiring with a power supply providing 24 Vdc.

Power supply voltage = 24 Vdc,
Eclipse minimum operating voltage = 18 Vdc

$$24 - 18 = 6 \text{ Vdc}$$

Maximum Voltage Drop = 6
Maximum Current = 0.31 A
Wire Resistance in Ohms/Foot = 0.006523

$$6 \div 0.31 \div 0.006523 \div 2 = 1484 \text{ feet}$$

NOTE

For FM/CSA/ATEX Certified systems using HART communication, the maximum wiring distance is 2000 feet.

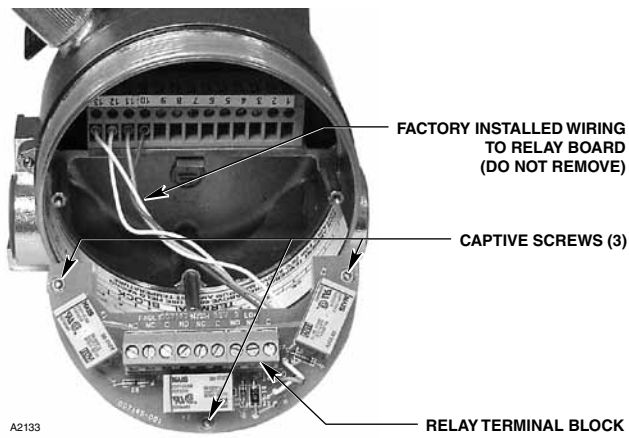

Figure 3—Eclipse Wiring Termination Compartment with Optional Relay Board Removed

OPTIONAL RELAYS

Optional relay contacts are “dry”, meaning that the installer must provide the voltage to the common terminal of the relay output.

AC voltage should not be switched directly using the Eclipse relays. The use of an external relay is required if AC voltage must be switched by the Eclipse relays.

In order to change alarm relay settings from the factory default settings, it is recommended to utilize a HART Field Communicator. Contact the factory for further assistance.

NOTE

Refer to “Alarm Relays” in the Specifications section of this manual for important information regarding alarm relays.

The relay board must temporarily be removed from the Eclipse termination compartment to connect the relay output field wiring cables. After the relay wiring is connected, re-install the relay board using the three captive screws. Refer to Figure 3.

WIRING PROCEDURE

Ensure that all cables are terminated properly. Pointwatch Eclipse screw terminal torque range is 3.5–4.4 in.-lbs. (0.4–0.5 N·m).

Conductor insulation should be stripped off with a bare conductor length of 0.2 inch (5 mm) minimum and 0.7 inch (18 mm) maximum.

Cable shield, if used, should be properly terminated. If not terminated, clip the shield wire off short and insulate it within the detector housing to prevent the shield wire from accidentally contacting the detector housing or any other wire.

Figure 4 shows the wiring terminal strip located inside the detector’s integral junction box.

Figure 5 shows the wiring terminal configuration for the standard Eclipse without relays.

Figure 6 shows the wiring terminal configuration for the standard Eclipse with relays.

Figures 7 through 10 show the 4-20 mA output of the Eclipse detector in various wiring schemes.

Figure 11 shows a standard Eclipse wired to a FlexVu UD10 Universal Display Unit.

Figure 12 shows a standard Eclipse wired to a Model U9500H Infiniti Transmitter.

Figure 13 shows a standard Eclipse wired to a Model R8471H Controller.

Figure 14 shows the wiring terminal configuration for the Eagle Quantum Premier Eclipse.

Figure 15 shows the Eclipse wired for benchtop testing/programming using HART protocol.

NOTE

The Eclipse housing must be electrically connected to earth ground. A dedicated earth ground lug is provided for this purpose.

REMOTE CALIBRATION WIRING

If it is desired to initiate calibration using the remote calibrate line, the use of the Det-Tronics Model PIRTB Termination Box is highly recommended for optimum ease of installation and calibration. The PIRTB module includes a magnetic reed switch, indicating LED, and wiring terminal block. Refer to “Remote Calibration Option” in the “Description” section of this manual for details.

Figure 16 shows the location of the wiring terminals, reed switch and LED inside the calibration termination box. See Figure 17 for wiring details.

WARNING

Do not attempt to physically connect or touch the calibration lead wire to DCV common in the field to begin calibration. This practice is often less than precise, and may result in a spark or other undesirable results. For optimum ease of installation and calibration, always utilize a Det-Tronics junction box with magnetic reed-switch, indicating LED, and termination block (Model PIRTB).

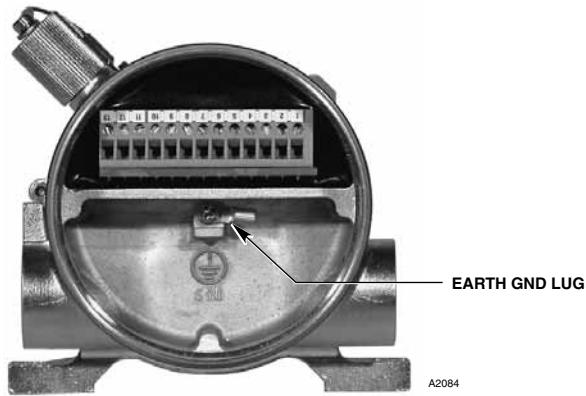

Figure 4—Terminal Strip Located Inside Wiring Compartment

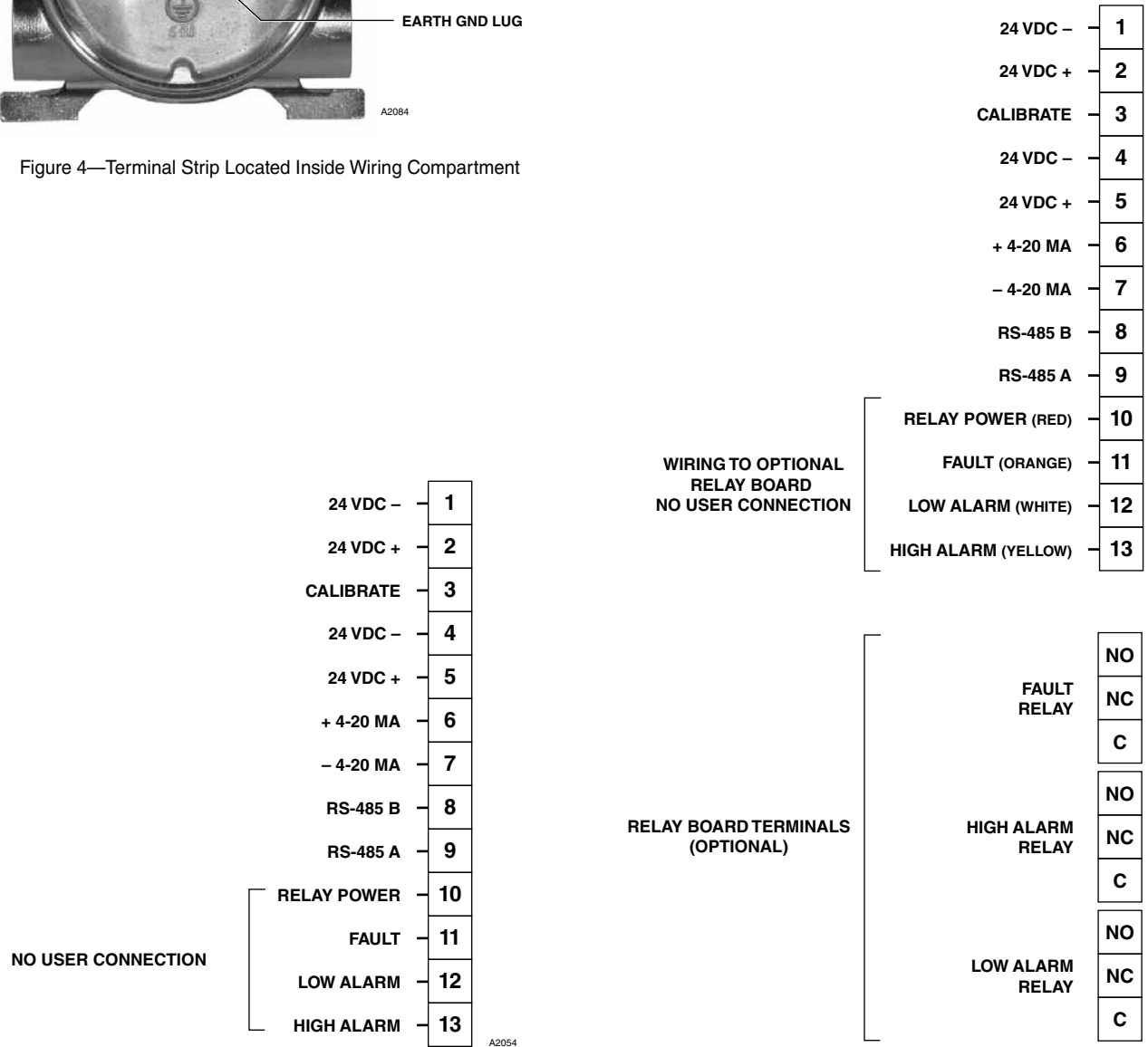
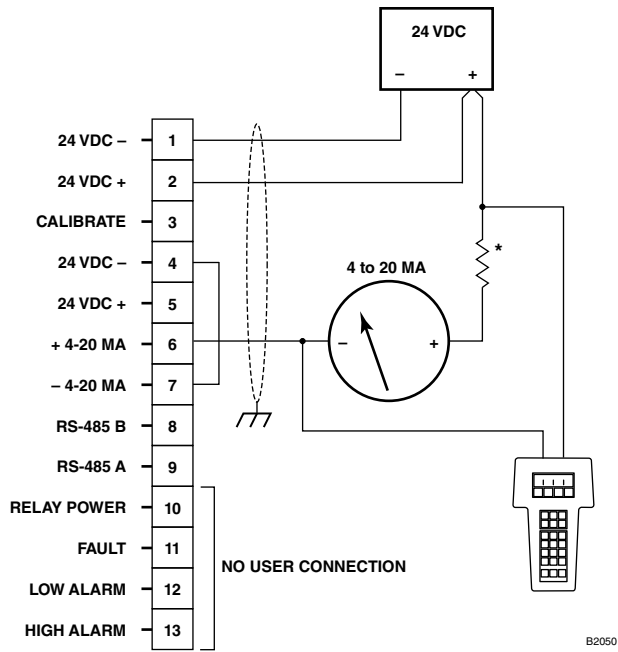

Figure 5—Wiring Terminal Identification for Standard Eclipse Without Relays

Figure 6—Wiring Terminal Identification for Standard Eclipse with Relays



*TOTAL LOOP RESISTANCE = 250 OHMS MINIMUM, 600 OHMS MAXIMUM.
DO NOT INSTALL RESISTOR WITHIN PIRECL ENCLOSURE IN EEx e APPLICATIONS.

Figure 7—Eclipse Detector Wired for Non-Isolated 4-20 mA Current Output (Sinking)

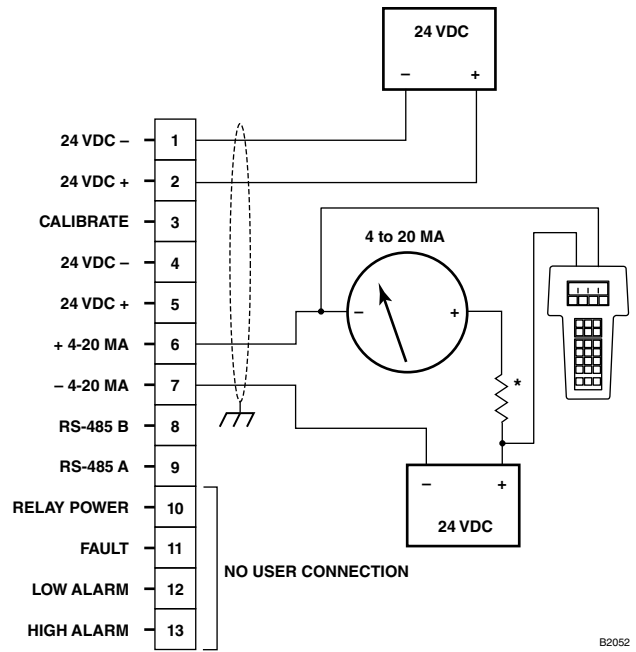

*TOTAL LOOP RESISTANCE = 250 OHMS MINIMUM, 600 OHMS MAXIMUM.
DO NOT INSTALL RESISTOR WITHIN PIRECL ENCLOSURE IN EEx e APPLICATIONS.

Figure 9—Eclipse Detector Wired for Isolated 4-20 mA Current Output (Sinking)

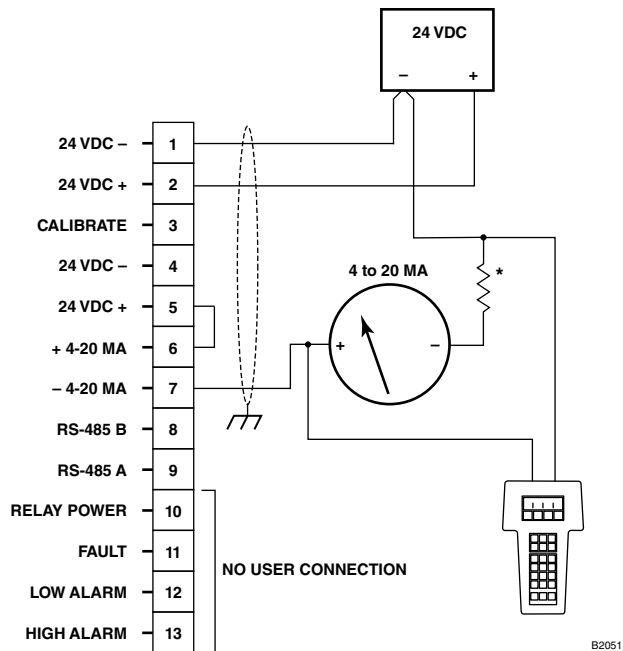

*TOTAL LOOP RESISTANCE = 250 OHMS MINIMUM, 600 OHMS MAXIMUM.
DO NOT INSTALL RESISTOR WITHIN PIRECL ENCLOSURE IN EEx e APPLICATIONS.

Figure 8—Eclipse Detector Wired for Non-Isolated 4-20 mA Current Output (Sourcing)

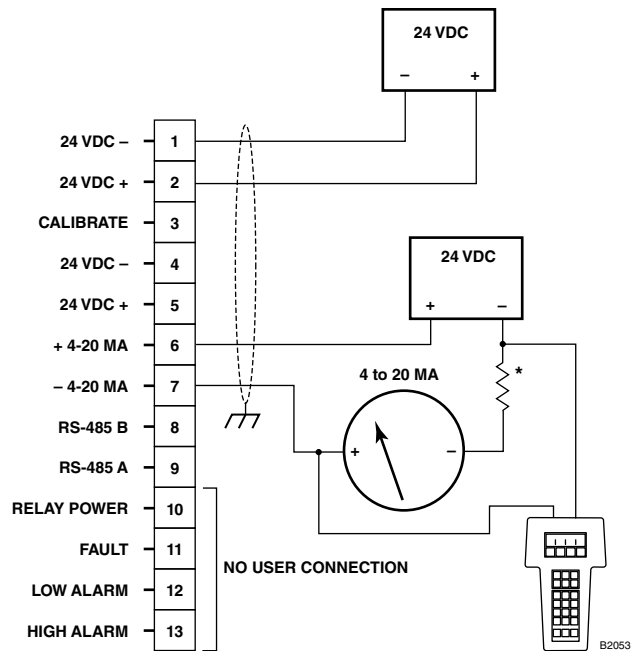

*TOTAL LOOP RESISTANCE = 250 OHMS MINIMUM, 600 OHMS MAXIMUM.
DO NOT INSTALL RESISTOR WITHIN PIRECL ENCLOSURE IN EEx e APPLICATIONS.

Figure 10—Eclipse Detector Wired for Isolated 4-20 mA Current Output (Sourcing)

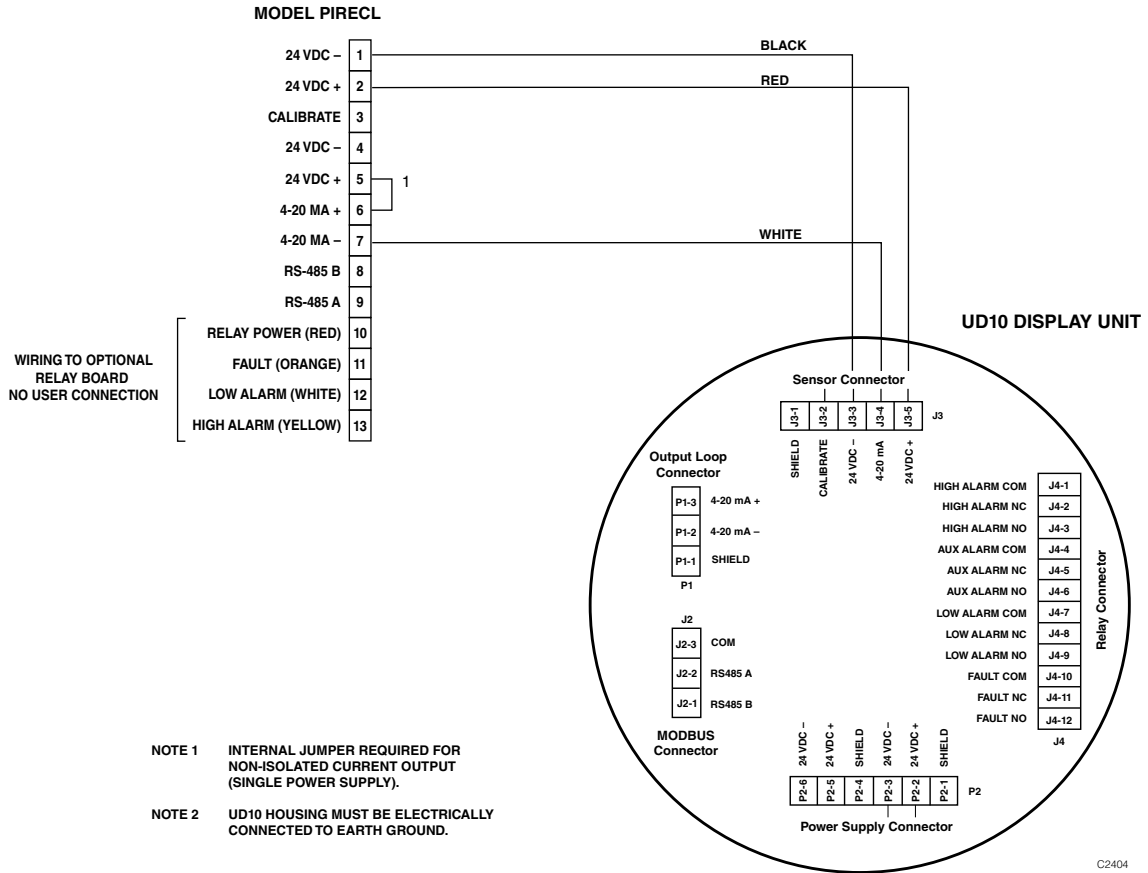
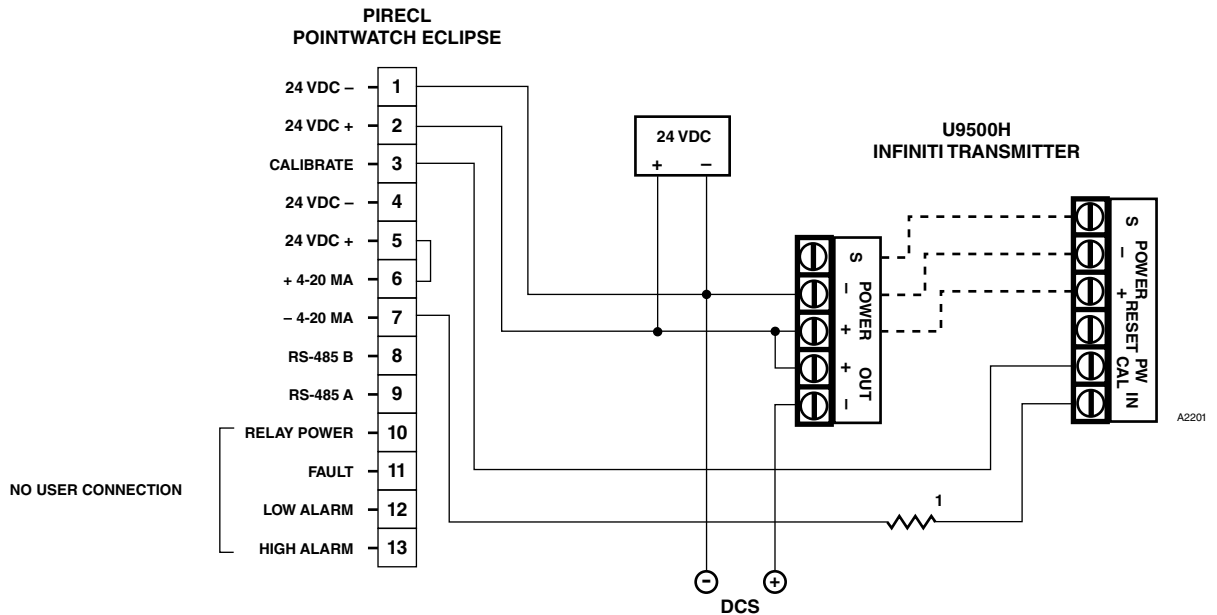

Figure 11—Standard Eclipse Wired to a Model UD10 Universal Display Unit



NOTES: 1 250 OHM RESISTOR REQUIRED IF USING HART PORT COMMUNICATIONS.

2 PIRECL ECLIPSE MUST BE PROGRAMMED TO PIR9400 FAULT MODE FOR PROPER STATUS IDENTIFICATION AT THE U9500H TRANSMITTER.

Figure 12—Standard Eclipse Wired to a Model U9500H Infiniti Transmitter

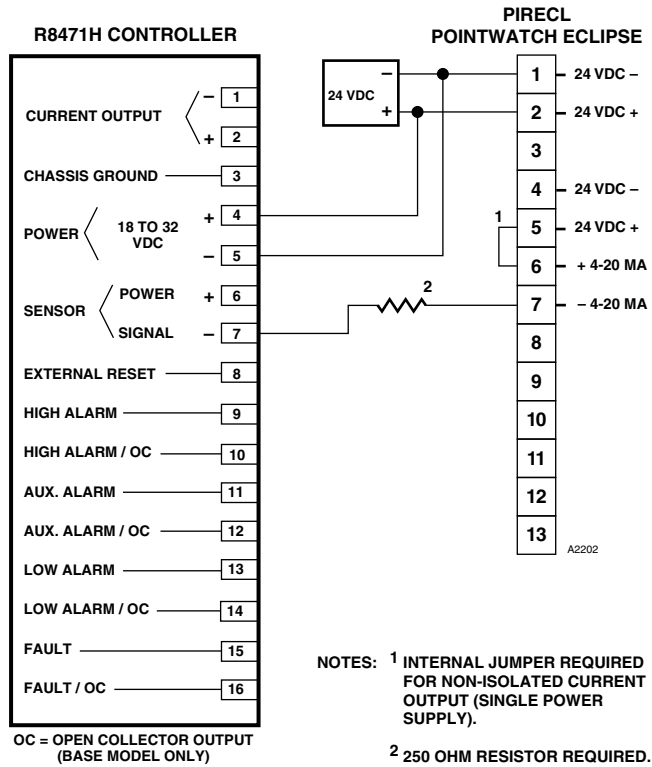

Figure 13—Standard Eclipse Wired to a Model R8471H Controller

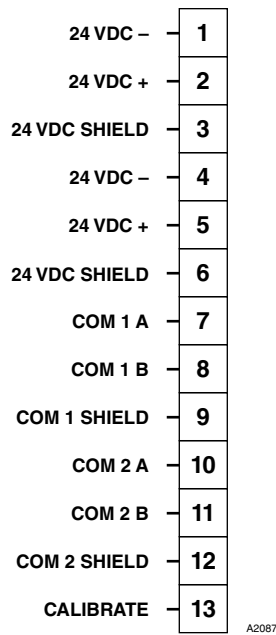

Figure 14—Wiring Terminal Identification for Eagle Quantum Premier Eclipse

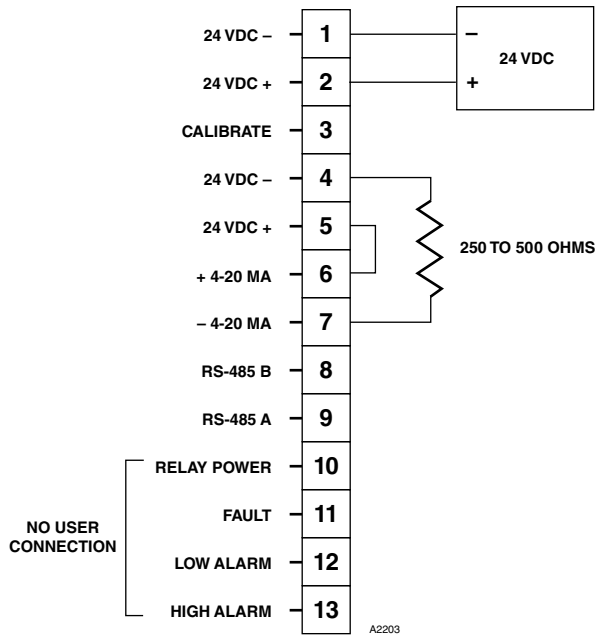

Figure 15—Wiring the Model PIRECL for Benchtop Testing/
 Programming Using HART Protocol

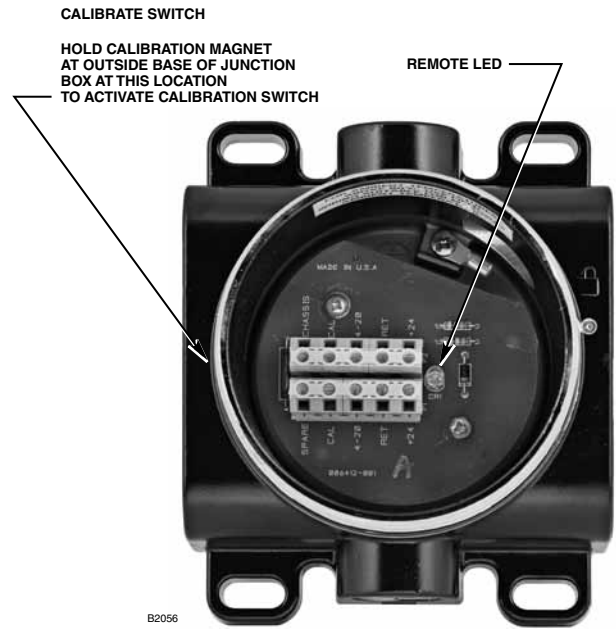
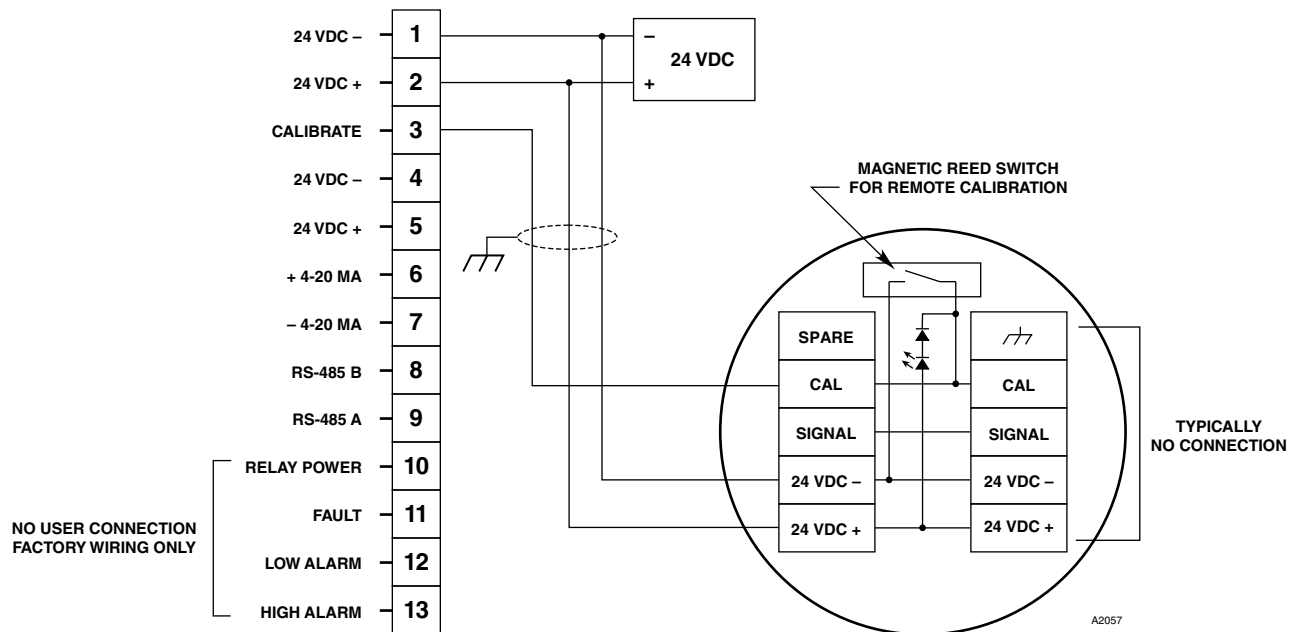

Figure 16—Remote Calibration Switch and LED in Optional Det-Tronics PIRTB Termination Box



NOTE: IF REQUIRED, POWER AND 4 TO 20 MA SIGNAL OUTPUT MAY BE ROUTED THROUGH REMOTE CALIBRATION MODULE USING SHIELDED CABLING.

Figure 17—Remote Calibration Module Wired to PointWatch Eclipse

DESCRIPTION

INTERNAL MAGNETIC SWITCH

An internal magnetic switch is provided for resetting latched alarms and initiating calibration. See Figure 18 for switch location. Momentary switch activation will reset alarms, while holding the switch closed for 2 seconds or longer will start the calibration sequence. The switch can also be used to enter "live" calibration mode or terminate the calibration sequence (see "Calibration" section).

HART COMMUNICATION

An optional intrinsically safe HART communication port provides a non-intrusive means for connecting the HART Communicator to the Eclipse. Refer to Figure 19.

Alternatively, the HART communicator can be connected across a 250 ohm resistor in the 4-20 mA loop.

NOTE

All Eclipse gas detectors (except EQP models) are furnished with HART capability. However, a 250 ohm resistor must be present within the 4-20 mA loop for HART communication to work. In many cases, this resistor is already present in the control panel. For a bench test or a situation where the 4-20 mA loop is not active, this resistor must still be installed for HART communication to function properly (see Figure 15).

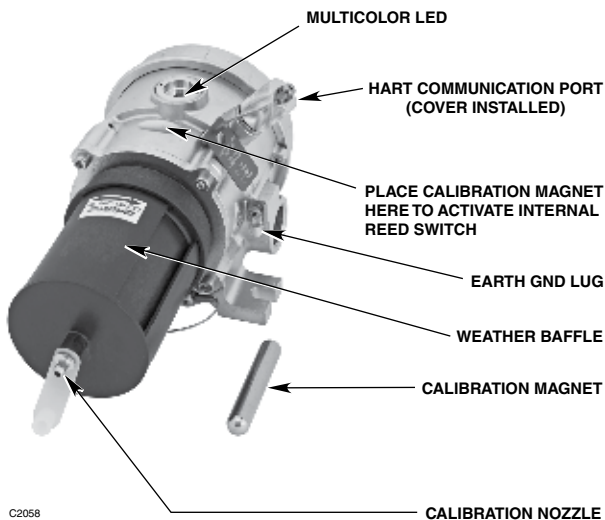

Figure 18—PointWatch Eclipse

If a PIRTB Remote Calibration Termination Box is utilized, the HART Communicator can be connected at the PIRTB. Note that this connection requires removal of the PIRTB cover.

Connect the HART Communicator, then turn it on by pressing the ON/OFF key. The communicator will indicate when the connection is made. If the connection is not made, the communicator will indicate that no device was found. Refer to the HART appendix in this manual for complete information.

WARNING

For Division applications, do not open cover when explosive gas atmosphere may be present.

Refer to Appendix A in this manual for complete information regarding HART communication with Eclipse.

I.S. HART PORT NOT PROVIDED ON THIS MODEL



HART COMMUNICATOR CONNECTED TO I.S. HART PORT



Figure 19—Eclipse Models with and without IS HART Port

Table 1—LED Status Indication

LED	Device Status
Green	Normal operation.
Red	Blinking indicates Low Alarm. On steady indicates High Alarm.
Yellow	Fault condition or warmup.

MULTICOLOR LED

An onboard multi-color LED is provided for indicating faults, alarms, and calibration status. See Table 1. LED operation for fault status is non-latching. LED operation for alarms is configurable for latching/non-latching.

WEATHER BAFFLE ASSEMBLY

The black weather baffle is provided to prevent debris and water from entering the optics, while allowing gases and vapors to enter readily. An O-ring is provided on the main Eclipse body to ensure a proper seal with the weather baffle. Two weather baffle configurations are available — one with an internal hydrophobic filter and one without the internal hydrophobic filter.

The weather baffle version with hydrophobic filter is recommended for most outdoor and indoor applications, especially wet and/or dirty applications. When compared to the weather baffle version without the hydrophobic filter, it provides optimum protection against airborne water and dirt, with minimal reduction in speed of gas alarm response.

The weather baffle assembly is not field-serviceable, but is easily replaceable. To remove the plastic weather baffle from the Eclipse body, rotate it one quarter turn counter-clockwise and pull.

The weather baffle is furnished with a calibration gas nozzle for direct injection of gas to the sensor, allowing the operator to apply gas to the detector without going through the weather baffle.

NOTE

Always cover the calibration gas nozzle with the cap during normal operation, and ensure that the cap is not damaged.

CLOCK

An hour meter is provided to give a relative indication of time for historical logs. The meter is zeroed at the time of manufacture and only increments while power is applied. HART or MODBUS communication is required to view the running hours.

HISTORY LOGS

All history logs are saved in non-volatile memory and retained through power cycles. HART or MODBUS communication is required to view the history logs.

Event Log (Alarms and Faults)

An event log saves the ten most recent alarms and a selected group of faults with an hour meter time stamp. HART or MODBUS communication is required to view the log. Types of logged events include:

- Low Alarms
- High Alarms
- Optics Fault
- Warm-up
- Calibration Fault

Calibration Log

A log of the ten most recent calibrations with time stamp is saved. HART or MODBUS communication is required to view the log. Types of calibration records include:

- Zero Only Calibration
- Complete Calibration
- Failed Calibration

Min/Max Temperature History

Ambient minimum and maximum exposed temperature measurements are stored in non-volatile memory, and are accessible via HART or MODBUS communication. The measurements are time tagged with respect to total hours of powered operation. The temperature log may be reset, in which case all min/max exposed temperature logs are cleared.

REMOTE CALIBRATION OPTION

In most applications, it is recommended to install the Pointwatch Eclipse where it will contact the vapor of interest as quickly as possible. Unfortunately, the best location for early warning can often result in accessibility problems for the operator when calibration is required. In these applications, the Model PIRTB Termination Box is highly recommended to provide the ability to calibrate the Pointwatch Eclipse from a remote location.

The PIRTB consists of a termination/circuit board, housed within an explosion-proof junction box. The circuit board contains a magnetic reed switch for initiating calibration, an indicating LED to signal the operator when to apply and remove the calibration gas, and a wiring terminal block. The junction box cover is furnished with a small viewing window that enables calibration to be performed without hazardous area de-classification. The PIRTB may be installed up to 100 feet away from the Eclipse. Refer to Figure 20 for remote calibration configuration options.

NOTE

The remote calibration switch is intended for initiating calibration only. Resetting latching alarm outputs using the remote calibration switch cannot be accomplished without entering the Calibration mode.

The following recommendations are provided to enhance operator ease and convenience of remote calibration configurations:

1. Install the Eclipse in such a manner that the onboard LED is visible whenever possible. This will aid in checking device status "at a glance."
2. The Eclipse is provided with a calibration gas nozzle on the weather baffle, which allows the use of permanently attached calibration gas delivery tubing (either polyethylene or stainless steel). The tubing is typically routed in parallel with the remote calibration cabling to the same location as the PIRTB termination box. This arrangement enables a technician to initiate calibration and deliver the calibration gas to the Eclipse from a single location.
3. When permanently installed calibration gas tubing is utilized, always install a shut-off valve at the open end to prevent unwanted vapors or debris from entering the tubing.
4. Always purge the permanent tubing with clean, dry compressed air prior to and immediately after calibration to ensure that residual combustible gases are cleared. Always close the shutoff valve after post-calibration purging is complete. This will ensure that all hydrocarbon vapors are eliminated from the Eclipse optics.
5. Note that permanently installed calibration gas tubing will increase the calibration gas consumption rate as a function of total tubing length.

Other methods of remote Eclipse calibration include utilizing HART or MODBUS communications. Refer to the HART and MODBUS appendices for details.

SPECIAL APPLICATIONS

The standard Pointwatch Eclipse is intended for open area combustible gas detection applications. However, special detector configurations are available for applications such as duct-mounting and sample extraction. Contact Detector Electronics Corporation for information on these special device configurations.

HAZARDOUS LOCATION

NON-HAZARDOUS LOCATION

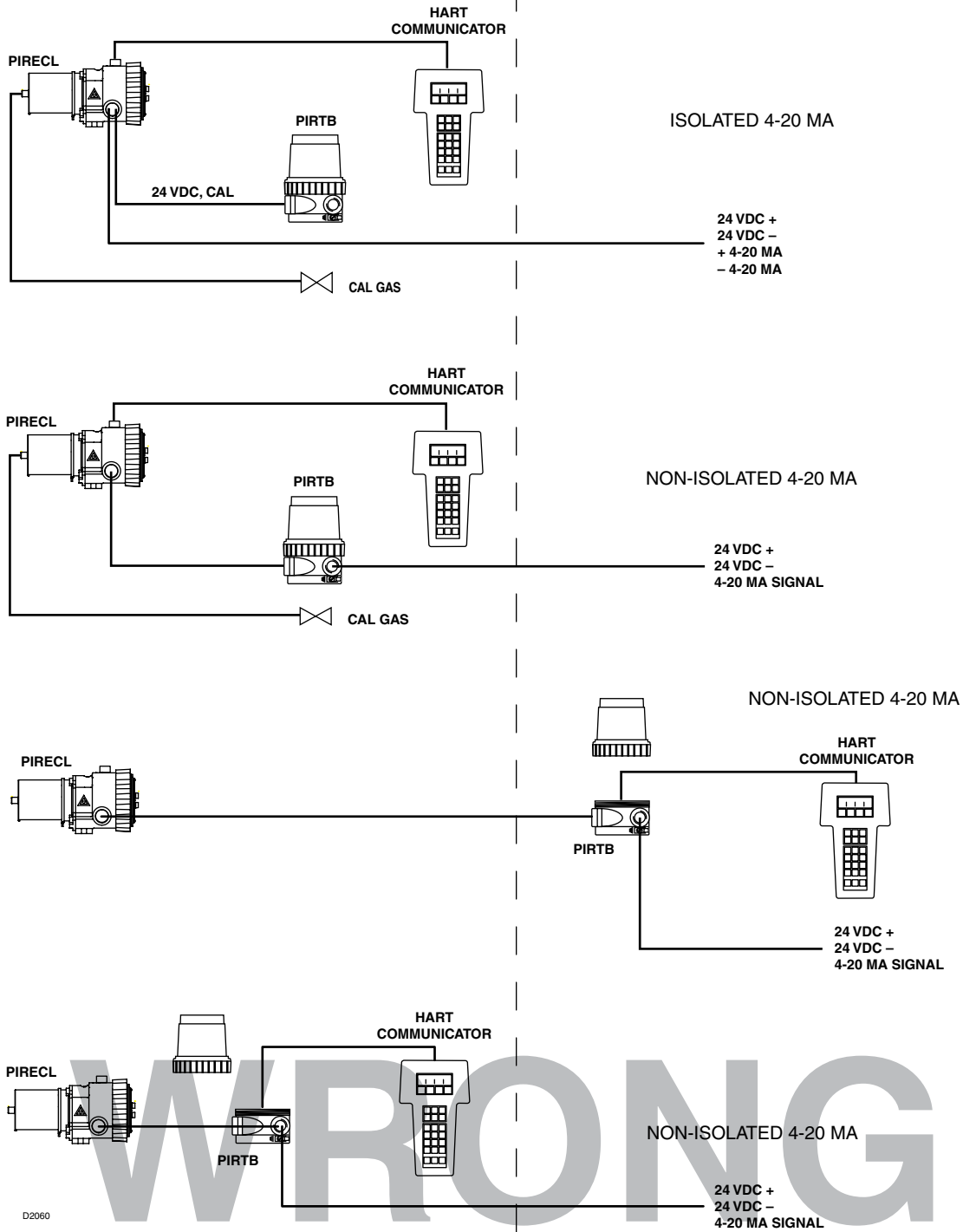

NOTE: THE TOTAL WIRING DISTANCE FROM THE HART COMMUNICATOR THROUGH THE POINTWATCH ECLIPSE TO THE SIGNAL RECEIVER MUST NOT EXCEED 2000 FEET (610 METERS).

Figure 20—Remote Calibration Configuration Options

OPERATION

FACTORY DEFAULT SETTINGS

The Pointwatch Eclipse is shipped from the factory pre-calibrated and set for detection of 0-100% LFL methane. Detection of gases other than methane will require changing the factory gas setting and performing field calibration of the device. HART or MODBUS communication is required to change the factory default settings. Refer to the HART Communications Appendix within this document for additional guidance.

OPERATING MODES

The Eclipse has three operating modes: warm-up, normal, and calibrate.

Warm-up

Warm-up mode is entered upon application of 24 Vdc operating power. During warm-up, the 4-20 mA current loop output will indicate warm-up, the indicating LED is yellow, and the alarm outputs are disabled. The warm-up mode lasts nominally two (2) minutes after power-up.

Normal

After warm-up mode is completed, the device automatically enters the Normal mode, and all analog and alarm outputs are enabled.

Calibrate

Calibration of the Eclipse is normally not required; however, the user has the option to verify proper calibration or to perform calibration procedures if necessary. Guidelines for when to perform a calibration or a response test are listed in Table 2. The user has the choice of three methods to place the device into the Calibrate mode. Refer to the "Calibration" section in this manual for details.

Table 2—Calibration or Response Test

Function	Calibration	Response Test
Startup		X
Gas selection changed	X	
Non-standard gas (using linearization other than methane)	X	
Replace any part	X	
Constant zero offset	X	
Periodic Functional Testing (at least once a year)		X

4-20 MA CURRENT LOOP OUTPUT

Eclipse provides an isolated, linear current loop output that is proportional to the detected gas level. Fault and calibration status are also indicated by this output.

The factory default for full-scale 100% LFL output is 20 mA. Other full scale values (from 20 to 100% LFL) can be selected using HART or MODBUS communication. HART and MODBUS interfaces also have the ability to calibrate the 4 mA and 20 mA levels.

When the default setting is selected, the LFL percentage for a given current reading can be calculated using the formula:

$$\% \text{ LFL} = (X - 4) \div 0.16 \quad X = \text{Current reading in milliamperes}$$

Example: Device reads 12 mA.

$$12 - 4 = 8$$

$$8 \div 0.16 = 50$$

50% LFL is indicated.

Normally, the current loop output is proportional to the selected standard gas type only. Refer to Appendix C within this document for information on non-standard gas detection.

FAULT INDICATION

There are three modes of signaling faults using the 4-20 mA analog signal output:

- PIR9400 (Factory default setting, used for retrofit applications of the PIR9400 detector)
- Eclipse
- User Defined

Fault signaling mode can be selected using the HART or MODBUS interface. Table 3 shows the current levels for each fault mode.

PIR9400 Fault Mode

This mode is provided for compatibility with existing Det-Tronics PointWatch gas detectors. The fault and calibration levels are identical to existing PIR9400 units, which makes the Eclipse compatible with the U9500 Infiniti Transmitter. As with the PIR9400 detector, live and suppressed “signal during calibration” modes are available.

Eclipse Fault Mode

Eclipse mode follows conventional fault signaling practice. The current loop output indicates the presence of a fault, but does not attempt to identify a specific fault with a specific current output value. Identification of a specific fault type is done through the HART Communicator or MODBUS.

User Defined Fault Mode

This mode is intended for users who wish to program unique current levels for faults and calibration signals. User defined current levels can be set from 0.0 to 24.0 mA. and can be programmed from HART or MODBUS interfaces. Four unique current levels are available: warm-up, general fault, calibration, and blocked optics.

Table 3—Output Levels of 4-20 mA Current Loop and Corresponding Status Indications

Condition	PIR9400 Fault Mode	Eclipse Fault Mode	User Defined Fault Mode
Gas Level (-10% to 120% Full scale)	2.4 to 23.20	2.4 to 23.20	2.4 to 23.20
Warm-up	0.00	1.00	Warm-up
Reference Sensor Saturated	0.20	1.00	General Fault
Active Sensor Saturated	0.40	1.00	General Fault
Calibration line active on power-up	0.60	1.00	General Fault
Low 24 volts	0.80	1.00	General Fault
Low 12 volts	1.20	1.00	General Fault
Low 5 volts	1.20	1.00	General Fault
Dirty Optics	1.00	2.00	Blocked Optics
Calibration Fault	1.60	1.00	General Fault
Calibration complete	1.80	1.00	Calibration
Span calibration, apply gas	2.00	1.00	Calibration
Zero calibration in progress	2.20	1.00	Calibration
Negative signal output fault	2.40	1.00	General Fault
Flash CRC	1.20	1.00	General Fault
Ram Error	1.20	1.00	General Fault
EEPROM Error	1.20	1.00	General Fault
IR Source Failure	1.20	1.00	General Fault

STARTUP

When the Eclipse is installed and wired as described in the "Installation" section, it is ready for commissioning. If the application requires that specific changes be made to the factory settings, HART, MODBUS or EQP communication will be required. Refer to the appropriate Appendix for details.

NOTE

Ensure that controller alarm outputs are inhibited for a minimum of 10 seconds after system power-up to prevent unwanted output actuation.

NOTE

The safety function (gas input-to-actuation/notification) must always be verified upon completion of installation and/or modification.

PIRECL STARTUP/COMMISSIONING CHECKLISTS

Electrical Checklist

- All 24 Vdc power conductors are properly sized and are properly terminated.
- The 24 Vdc power supply provides sufficient load capacity for all gas detectors.
- Using a DC voltmeter, 24 Vdc has been measured at the detector.
- All signal output conductors are properly terminated, and the jumper wire is installed if a non-isolated signal output is desired.
- All relay contact output signal conductors are properly terminated if applicable.
- All screw terminals have been tightened and all wires pull-tested to confirm proper termination has been accomplished.

Mechanical Checklist

- PIRECL detector is mounted to a solid surface not prone to high vibration, shock, traumatic impact or other undesirable condition.
- PIRECL detector is installed in proper orientation (horizontal).
- PIRECL detector is installed to achieve weatherproof status, e.g. conduit seals or cable glands have been properly installed. If there is an unused conduit entry, this entry has been sealed with a weathertight plug.
- PIRECL detector threaded covers are tightened to engage all O-rings.
- The hex head set screw is tightened to secure the cover and prevent access to the wiring compartment without the use of a tool.

Gas Detection and Measurement Checklist

- Vapor(s) to be detected have been identified, and appropriate calibration gas setting for the PIRECL has been confirmed.
- Area(s) of coverage have been identified, and optimum detector locations for installation are documented.
- Detector installation location is suitable for intended purpose, e.g. no obvious impediments to contact with the gas or vapor of interest exist or are likely to exist.
- Proper calibration gas(es) are available to perform proof of response test or calibration during commissioning.
- HART communicator or similar field communicator is available if field programming is expected or required.
- Calibration magnet is available to initiate quick calibration or reset.

CALIBRATION

CALIBRATION OVERVIEW

Although routine calibration of the Pointwatch Eclipse is normally not required, the device supports non-intrusive field calibration capability. Two (2) calibration procedure options are provided:

1. **Normal Calibration** is a two-step process consisting of clean air (zero) condition and mid-scale (span) adjustment. Calibration gas must be applied by the operator to enable span adjustment. Normal calibration is required whenever the gas type setting has been changed from the factory-default methane setting. Purge the Eclipse optics with clean, dry air prior to calibration initiation to ensure that an accurate zero (clean air) condition is present.

The following Normal Calibration guidelines always apply:

- A. The Eclipse is factory set for detection of methane. If the gas setting is changed (using HART, MODBUS or EQP communication), the Eclipse **must** be re-calibrated (normally with the matching gas type).
 - B. The calibration gas type normally should match the selected gas setting for the Eclipse. Different calibration gas types are selectable using HART, MODBUS or EQP communication. The factory default calibration gas is methane.
 - C. The recommended calibration gas concentration is 50% LFL, although other calibration concentrations may be utilized if previously defined in the Eclipse using HART, MODBUS or EQP communication.
2. **Zero Only Calibration** is a one-step process consisting of clean air (zero) condition adjustment only, which is performed automatically by the device. This procedure adjusts the "clean air" signal output only, and is normally used if the 4 milliamperes signal level has drifted. The cause of drift is typically due to the presence of background gas during calibration. Purge the Eclipse optics with clean, dry compressed air prior to calibration initiation to ensure an accurate zero (clean air) condition is present.

ADDITIONAL CALIBRATION NOTES

IMPORTANT

Always ensure that the correct gas type is used for calibration. (2.5 LPM flow rate is recommended.)

NOTE

Ensure that the detector has been operating for at least two hours before calibrating.

NOTE

Always ensure that the Eclipse optics are totally free of all hydrocarbons before initiating calibration. This may require purging of the Eclipse with pure air prior to initiating calibration.

NOTE

Under very windy conditions, it may not be possible to successfully calibrate the Eclipse. This situation is easily corrected by using the Eclipse Calibration Bag (P/N 006672-002), available from Det-Tronics.

NOTE

Always place the protective cap back on the calibration nozzle after completion of span calibration.

CALIBRATION INITIATION

Eclipse calibration may be initiated by any of the following means:

- The onboard magnetic calibration switch
- The magnetic calibration switch in the remote termination box
- HART communication.

Calibration using Magnetic Switch

1. Onboard Switch and LED

The Pointwatch Eclipse provides an onboard magnetic calibration/reset switch for non-intrusive calibration capability. The magnetic switch is located on the device bulkhead. See Figure 18 for switch location. An onboard tri-color LED is also provided to signal the operator when to apply and remove calibration gas.

2. Remote Switch and Indicating LED

A special Remote Termination Box (Model PIRTB) is available for initiating calibration from a remote location. The PIRTB provides an internal magnetic switch and indicating LED (LED is on/off only, not tri-color). The PIRTB is provided with a clear window on the cover, enabling non-intrusive calibration capability.

Either magnetic switch must be actuated for 2 seconds using a calibration magnet to initiate Eclipse calibration. Upon initiation, the Eclipse automatically performs the zero calibration adjustment, and then signals the operator when it is time to apply calibration gas. Upon completion of the span adjustment, the Eclipse returns to normal mode after the calibration gas has cleared. The indicating LED (either onboard LED or PIRTB LED, if used) provides visual signals to the operator regarding the proper time to apply and remove the calibration gas.

For Zero Only Calibration, the operator must re-actuate the magnetic switch upon LED signal to apply calibration gas. This action instructs the Eclipse to utilize the previous span setting, and return to normal mode without requiring application of calibration gas.

Digital Communication Calibration

HART, MODBUS or EQP communication may be utilized to initiate Eclipse calibration. Refer to the appropriate appendix for details.

DETAILED CALIBRATION PROCEDURE USING MAGNETIC SWITCH

Refer to Tables 4 and 5 for a quick summary of the standard calibration sequence.

1. Apply magnet for 2 seconds minimum to initiate calibration.
 - A. The onboard LED turns to steady red.
 - B. The LED within the PIRTB (if used) turns on.
 - C. The Eclipse current output decreases from 4 mA to 1 mA when the default Eclipse calibration routine is used.
2. When Zero Calibration is complete:
 - A. The onboard LED changes from steady red to flashing red.
 - B. The LED within the PIRTB (if used) begins flashing.
 - C. The Eclipse current output does not change from the 1 mA level when the default Eclipse calibration routine is used.
 - D. The operator should now apply the appropriate calibration gas to the Eclipse if conducting Normal Calibration.
 - E. If conducting Zero Only Calibration, the operator should re-apply the magnet to the switch. This will conclude the Zero Only calibration sequence.
3. When Span Calibration is complete:
 - A. The onboard LED changes from flashing red to "off".
 - B. The operator should now close the valve and remove the calibration gas from the Eclipse.

NOTE

It is normal for the Eclipse LED to go off or turn blank (no color displayed) until the calibration gas is cleared from the optics chamber. Remove the weather baffle if necessary to clear residual gas.

- A. The LED within the PIRTB (if used) changes to steady on.
- D. The Eclipse current output does not change from the 1 mA level when the default Eclipse calibration routine is used.

Table 4—Quick Reference Guide for Normal Calibration Procedure Using Magnetic Switch

Description	Indicating LED (on-board/PIRTB)	Current Output (default setting)	Operator Action
Normal-ready to calibrate	steady green/off	4 mA	Purge with clean air if required
Initiate Calibration	steady red/on-steady	1 mA	Apply Magnet for 2 seconds min.
Zero Calibration complete	flashing red/on-flashing	1 mA	Apply Calibration Gas to device
Span Calibration in progress	flashing red/on-flashing	1 mA	Continue cal gas flow
Span Calibration complete	off/on-steady	1 mA	Remove Calibration Gas
Output Returns to Normal	steady green/off	4 mA	Calibration Completed
Normal Operation	steady green/off	4 mA	None

Table 5—Quick Reference Guide for Zero Only Calibration Procedure Using Magnetic Switch

Description	Indicating LED (on-board/PIRTB)	Current Output (default setting)	Operator Action
Normal-ready to calibrate	steady green/off	4 mA	Purge with clean air if required
Initiate Calibration	steady red/on-steady	1 mA	Apply Magnet for 2 seconds min.
Zero Calibration complete	flashing red/on-flashing	1 mA	Re-initiate magnetic switch to terminate calibration
Return to Normal Mode	steady green/off	4 mA	Zero Calibration Completed

4. Return to Normal is complete when:
 - A. The onboard LED changes from “off” to steady green.
 - B. The LED within the PIRTB (if used) turns off.
 - C. The Eclipse current output returns to 4 mA after detected calibration gas level drops below 5% LFL or the calibration abort signal is provided.

CALIBRATION ABORT

Calibration can be aborted at any time after zero calibration is completed. This is done by activating the onboard or PIRTB magnetic switch, or by a command from the HART, MODBUS or EQP interface. If calibration is terminated, the new zero point is retained, and a zero calibration code is saved in the calibration history buffer. The unit will immediately return to normal operation.

TIME OUT

If calibration is not completed within 10 minutes, a calibration-failed fault is generated, and the unit returns to normal operation using the previous calibration values.

NOTE

Under normal conditions, span calibration is typically completed in 3 minutes or less.

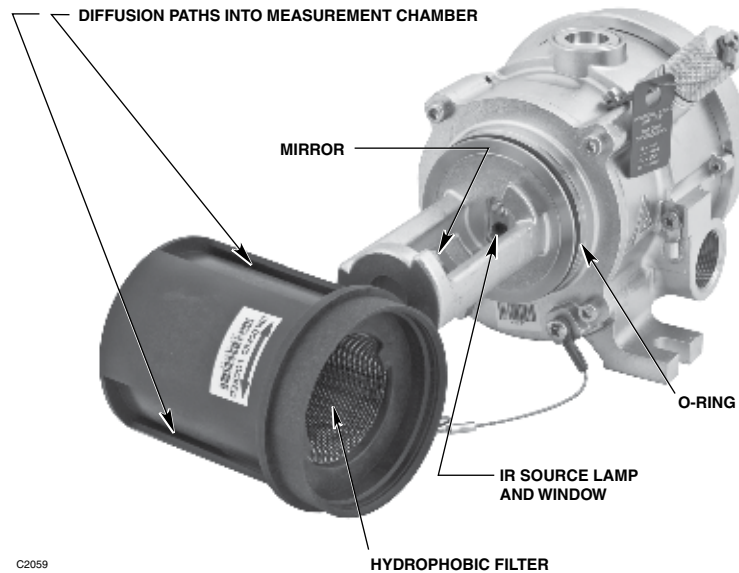

Figure 21—PointWatch Eclipse with Baffle Removed

MAINTENANCE

ROUTINE INSPECTION

The PointWatch Eclipse detector should be inspected periodically to ensure that external obstructions such as plastic bags, mud, snow, or other materials do not block the weather baffle, thereby impairing the performance of the device. In addition, the weather baffle assembly should be removed and inspected to ensure that the diffusion paths into the measurement chamber are clear. See Figure 21.

WEATHER BAFFLE CLEANING

Remove the weather baffle assembly and clean with a soft brush and soap and water. Rinse and allow to dry.

Replace the weather baffle if damaged or if fouling of the baffle vents is evident.

NOTE

Solvents may damage the weather baffle assembly. If contamination is not removed using soap and water, then replacement of the baffle may be required.

OPTICS CLEANING

Cleaning of the Eclipse optical surfaces is normally required only if an optical fault is indicated.

Thoroughly douse the mirror and window using a liberal amount of isopropyl alcohol to clear away contaminant particles. Repeat the alcohol flush to remove any remaining contaminants. Allow the assembly to air-dry in a dust-free location.

O-RING

Periodically the O-ring should be inspected for breaks, cracks and dryness. To test the ring, remove it from the enclosure and stretch it slightly. If cracks are visible, it should be replaced. If it feels dry, a thin coating of lubricant should be applied. See “Spare Parts” section for recommended lubricant. When re-installing the ring, be sure that it is properly seated in the groove.

PROTECTIVE CAPS AND COVERS

The calibration nozzle cap must always be installed, except while performing calibration. Also ensure that the HART Communication Port cover and the wiring compartment cover are installed and fully engaged.

TROUBLESHOOTING

A Fault status is indicated by a yellow LED and also by the 4-20 mA output. Refer to Table 6 to identify the fault type using the 4-20 mA output. (The operator must know which fault signaling mode has been programmed.) Refer to Table 7 for assistance in correcting malfunctions with the PointWatch Eclipse Detector.

DEVICE REPAIR AND RETURN

The Pointwatch Eclipse IR Hydrocarbon Gas Detector is not designed to be repaired in the field. If a problem should develop, first carefully check for proper wiring, programming and calibration. If it is determined that the problem is caused by an electronic failure, the device must be returned to the factory for repair.

Prior to returning devices or components, contact the nearest local Detector Electronics office so that a Service Order number can be assigned. A written statement describing the malfunction must accompany the returned device or component to expedite finding the cause of the failure.

Return all equipment transportation prepaid to the factory in Minneapolis.

Table 6—Using the 4-20 mA Output Level to Identify a Fault Condition

Condition	PIR9400 Fault Mode	Eclipse Fault Mode	User Defined Fault Mode
Gas Level (-10% to 120% Full scale)	2.4 to 23.20	2.4 to 23.20	2.4 to 23.20
Warm-up	0.00	1.00	Warm-up
Reference Sensor Saturated	0.20	1.00	General Fault
Active Sensor Saturated	0.40	1.00	General Fault
Calibration line active on power-up	0.60	1.00	General Fault
Low 24 volts	0.80	1.00	General Fault
Low 12 volts	1.20	1.00	General Fault
Low 5 volts	1.20	1.00	General Fault
Dirty Optics	1.00	2.00	Blocked Optics
Calibration Fault	1.60	1.00	General Fault
Calibration complete	1.80	1.00	Calibration
Span calibration, apply gas	2.00	1.00	Calibration
Zero calibration in progress	2.20	1.00	Calibration
Negative signal output fault	2.40	1.00	General Fault
Flash CRC	1.20	1.00	General Fault
Ram Error	1.20	1.00	General Fault
EEPROM Error	1.20	1.00	General Fault
IR Source Failure	1.20	1.00	General Fault

Table 7—Troubleshooting Guide

Fault Condition	Corrective Action
Low 24 volts	24 vdc operating voltage is out of range. Verify proper wiring to the detector and correct voltage output from the power source. Power supply faults are self-clearing when the condition is corrected. If the fault does not clear, consult the factory.
Dirty Optics	Perform cleaning procedure, then recalibrate as required. (Refer to “Maintenance” for details.)
Calibration Fault	If the calibration process is allowed to time-out, the fault is set and can only be reset with a successful calibration. Check the gas bottle to ensure that there is enough gas to complete the calibration. Are conditions too windy for a successful calibration? If so, use a PointWatch Eclipse Calibration Bag (P/N 006672-002). Always calibrate with a Det-Tronics calibration kit for Eclipse with correct regulator. Be sure that the calibration gas being used matches the configured setting. If the fault is still present, perform cleaning procedure, then recalibrate.
Negative Signal Output	This fault is indicated when the signal output drops below –3% LFL. Normally detection capability is not compromised in this condition. The device was probably zero calibrated with background gas present. If the condition persists, purge with clean air and repeat the zero calibration.
Calibration line active at start-up	The only way to clear this fault is to correct the wiring and reapply power. Be sure that the calibration line is not shorted and that the calibration switch is open. If the fault does not clear, consult the factory.
Other Faults	Consult the factory.

ORDERING INFORMATION

POINTWATCH ECLIPSE DETECTOR

When ordering, please refer to the PIRECL Model Matrix.

CALIBRATION EQUIPMENT

Pointwatch Eclipse calibration kits consist of a sturdy carrying case containing two 3.6 cubic foot (103 liter) cylinders of specified gas, a regulator and pressure indicator, three feet of tubing, barbed nozzle for direct application to the device, and a calibration wind shield to contain the gas in high wind applications.

Methane, 50% LFL, 2.5% by volume	006468-001
Ethane, 50% LFL, 1.5% by volume	006468-002
Ethylene, 50% LFL, 1.35% by volume	006468-003
Propane, 50% LFL, 1.1% by volume	006468-004
Propylene, 50% LFL, 1% by volume	006468-005
PointWatch Eclipse Regulator	162552-002
Eclipse Calibration Bag	006672-002

SPARE PARTS

Weather Baffle with Inlet Nozzle, with Hydrophobic Filter	007165-002
Weather Baffle with Inlet Nozzle, without Hydrophobic Filter	007165-001
Weather Baffle w 1/16" NPT cal gas inlet, with Hydrophobic Filter	007165-004
Weather Baffle w 1/16" NPT cal gas inlet, without Hydrophobic Filter	007165-003
Calibration Port Cover	009192-001
Calibration Magnet	102740-002
Silicone Free Grease	005003-001
O-Ring, 3.75" i.d., for wiring compartment cover	107427-040
O-Ring, 3.25" i.d., for front flange (internal)	107427-053
O-Ring, 2.44" i.d., for weather baffle	107427-052

ASSISTANCE

For assistance in ordering a system to meet the needs of a specific application, contact:

Detector Electronics Corporation
 6901 West 110th Street
 Minneapolis, Minnesota 55438 USA
 Operator: (952) 941-5665 or (800) 765-FIRE
 Customer Service: (952) 946-6491
 Fax: (952) 829-8750
 Web site: www.det-tronics.com
 E-mail: det-tronics@det-tronics.com

PIRECL MODEL MATRIX

MODEL	DESCRIPTION														
PIRECL	Point Infrared Eclipse Gas Detector														
	<table border="1"> <thead> <tr> <th>TYPE</th> <th>THREAD TYPE</th> </tr> </thead> <tbody> <tr> <td>A</td> <td>3/4" NPT</td> </tr> <tr> <td>B</td> <td>M25</td> </tr> </tbody> </table>	TYPE	THREAD TYPE	A	3/4" NPT	B	M25								
TYPE	THREAD TYPE														
A	3/4" NPT														
B	M25														
	<table border="1"> <thead> <tr> <th>TYPE</th> <th>OUTPUT & MEASUREMENT OPTIONS</th> </tr> </thead> <tbody> <tr> <td>1</td> <td>4-20 mA with HART protocol & RS-485: 0-100% LFL Full Scale Range</td> </tr> <tr> <td>4</td> <td>Eagle Quantum Premier (EQP): 0-100% LFL Full Scale Range</td> </tr> </tbody> </table>	TYPE	OUTPUT & MEASUREMENT OPTIONS	1	4-20 mA with HART protocol & RS-485: 0-100% LFL Full Scale Range	4	Eagle Quantum Premier (EQP): 0-100% LFL Full Scale Range								
TYPE	OUTPUT & MEASUREMENT OPTIONS														
1	4-20 mA with HART protocol & RS-485: 0-100% LFL Full Scale Range														
4	Eagle Quantum Premier (EQP): 0-100% LFL Full Scale Range														
	<table border="1"> <thead> <tr> <th>TYPE</th> <th>OPTIONAL OUTPUTS</th> </tr> </thead> <tbody> <tr> <td>A</td> <td>HART Communication Port</td> </tr> <tr> <td>B</td> <td>HART Communication Port and Relay Board (Not compatible with EQP) Ex d only</td> </tr> <tr> <td>D</td> <td>No Optional Outputs</td> </tr> <tr> <td>E</td> <td>Relay Board (Not compatible with EQP) Ex d only</td> </tr> </tbody> </table>	TYPE	OPTIONAL OUTPUTS	A	HART Communication Port	B	HART Communication Port and Relay Board (Not compatible with EQP) Ex d only	D	No Optional Outputs	E	Relay Board (Not compatible with EQP) Ex d only				
TYPE	OPTIONAL OUTPUTS														
A	HART Communication Port														
B	HART Communication Port and Relay Board (Not compatible with EQP) Ex d only														
D	No Optional Outputs														
E	Relay Board (Not compatible with EQP) Ex d only														
	<table border="1"> <thead> <tr> <th>TYPE</th> <th>WEATHER PROTECTION</th> </tr> </thead> <tbody> <tr> <td>1</td> <td>Weather Baffle with Hydrophobic Filter</td> </tr> <tr> <td>2</td> <td>Weather Baffle without Hydrophobic Filter</td> </tr> <tr> <td>3</td> <td>Weather Baffle with Hydrophobic Filter and 1/16" Threaded Calibration Port</td> </tr> <tr> <td>4</td> <td>Weather Baffle without Hydrophobic Filter and 1/16" Threaded Calibration Port</td> </tr> <tr> <td>5</td> <td>No Weather Protection Installed</td> </tr> </tbody> </table>	TYPE	WEATHER PROTECTION	1	Weather Baffle with Hydrophobic Filter	2	Weather Baffle without Hydrophobic Filter	3	Weather Baffle with Hydrophobic Filter and 1/16" Threaded Calibration Port	4	Weather Baffle without Hydrophobic Filter and 1/16" Threaded Calibration Port	5	No Weather Protection Installed		
TYPE	WEATHER PROTECTION														
1	Weather Baffle with Hydrophobic Filter														
2	Weather Baffle without Hydrophobic Filter														
3	Weather Baffle with Hydrophobic Filter and 1/16" Threaded Calibration Port														
4	Weather Baffle without Hydrophobic Filter and 1/16" Threaded Calibration Port														
5	No Weather Protection Installed														
	<table border="1"> <thead> <tr> <th>TYPE</th> <th>APPROVALS</th> </tr> </thead> <tbody> <tr> <td>B</td> <td>Brazil</td> </tr> <tr> <td>R</td> <td>Russia</td> </tr> <tr> <td>T</td> <td>SIL/FM/CSA/ATEX/CE/IECEX</td> </tr> <tr> <td>U</td> <td>Ukraine</td> </tr> <tr> <td>W</td> <td>FM/CSA/ATEX/CE/IECEX</td> </tr> <tr> <td>Y</td> <td>China</td> </tr> </tbody> </table>	TYPE	APPROVALS	B	Brazil	R	Russia	T	SIL/FM/CSA/ATEX/CE/IECEX	U	Ukraine	W	FM/CSA/ATEX/CE/IECEX	Y	China
TYPE	APPROVALS														
B	Brazil														
R	Russia														
T	SIL/FM/CSA/ATEX/CE/IECEX														
U	Ukraine														
W	FM/CSA/ATEX/CE/IECEX														
Y	China														
	<table border="1"> <thead> <tr> <th>TYPE</th> <th>CLASSIFICATION*</th> </tr> </thead> <tbody> <tr> <td>1</td> <td>Division/Zone Ex de</td> </tr> <tr> <td>2</td> <td>Division/Zone Ex d</td> </tr> </tbody> </table>	TYPE	CLASSIFICATION*	1	Division/Zone Ex de	2	Division/Zone Ex d								
TYPE	CLASSIFICATION*														
1	Division/Zone Ex de														
2	Division/Zone Ex d														

*Detectors are always Class I, Div. 1.

APPENDIX A

HART COMMUNICATION

Digital communication with the Pointwatch Eclipse is necessary to monitor internal status and to modify the factory settings. This appendix provides guidance on establishing HART communication, and describes the communication menu structure when using the Eclipse with the HART Handheld Communicator.

ESTABLISHING LOCAL HART COMMUNICATION WITH POINTWATCH ECLIPSE

Unscrew the protective cap from the HART communication port on the side of the Eclipse gas detector. Connect the HART Communicator test probes to the two terminals inside the port (non-polarized). Press the "on" key to switch on the HART Handheld Communicator. The Online menu is the first menu to appear when the Communicator is properly connected to the Eclipse. This menu is structured to provide important information about the connected device. The HART protocol incorporates a concept called the "Device Description Language" (DDL) that enables HART instrument manufacturers to define and document their product in a consistent format. This format is readable by handheld communicators, PC's and other process interface devices that support DDL.

NOTES

Proper analog signal output termination and minimum loop resistance must be completed in all cases to enable HART communication. Failure to provide proper analog signal output loop resistance will preclude all HART communication.

It is possible to establish HART Communication with the PIRECL in Generic HART communication mode. In this mode, HART communication with the PIRECL detector will be established, but the Communicator will not recognize the PIRECL as a gas detector. Generic HART communication will not provide access to the PIRECL DDL menu and important set-up, diagnostics or operation functions, including gas type selection.

PROCEDURE TO DETERMINE IF ECLIPSE DDL IS PRESENT IN YOUR COMMUNICATOR

1. From the Main menu, select the Offline menu.
2. From the Offline menu, select New Configurations to access the list of device descriptions programmed into your HART Communicator. The Manufacturer menu displays a list of each manufacturer with available DDLs.
3. Select a manufacturer, and the display will show the list of available device types.
4. If you cannot find the Eclipse device on your Communicator, the specific DDL is not programmed into the Memory Module. Your HART Communicator will require a DDL upgrade in order to access all Eclipse DDL functions.

The HART Communication Foundation (www.hartcomm.org) manages the HCF Approved DDL Library and programming sites for HCF Approved field communicators. A complete listing of the DD Library is available for download and provides manufacturer and device type file identification.

ECLIPSE HART MENU STRUCTURE

This section displays the menu trees for the Pointwatch Eclipse. The Menu tree shows the primary commands and options available when using menu selections.

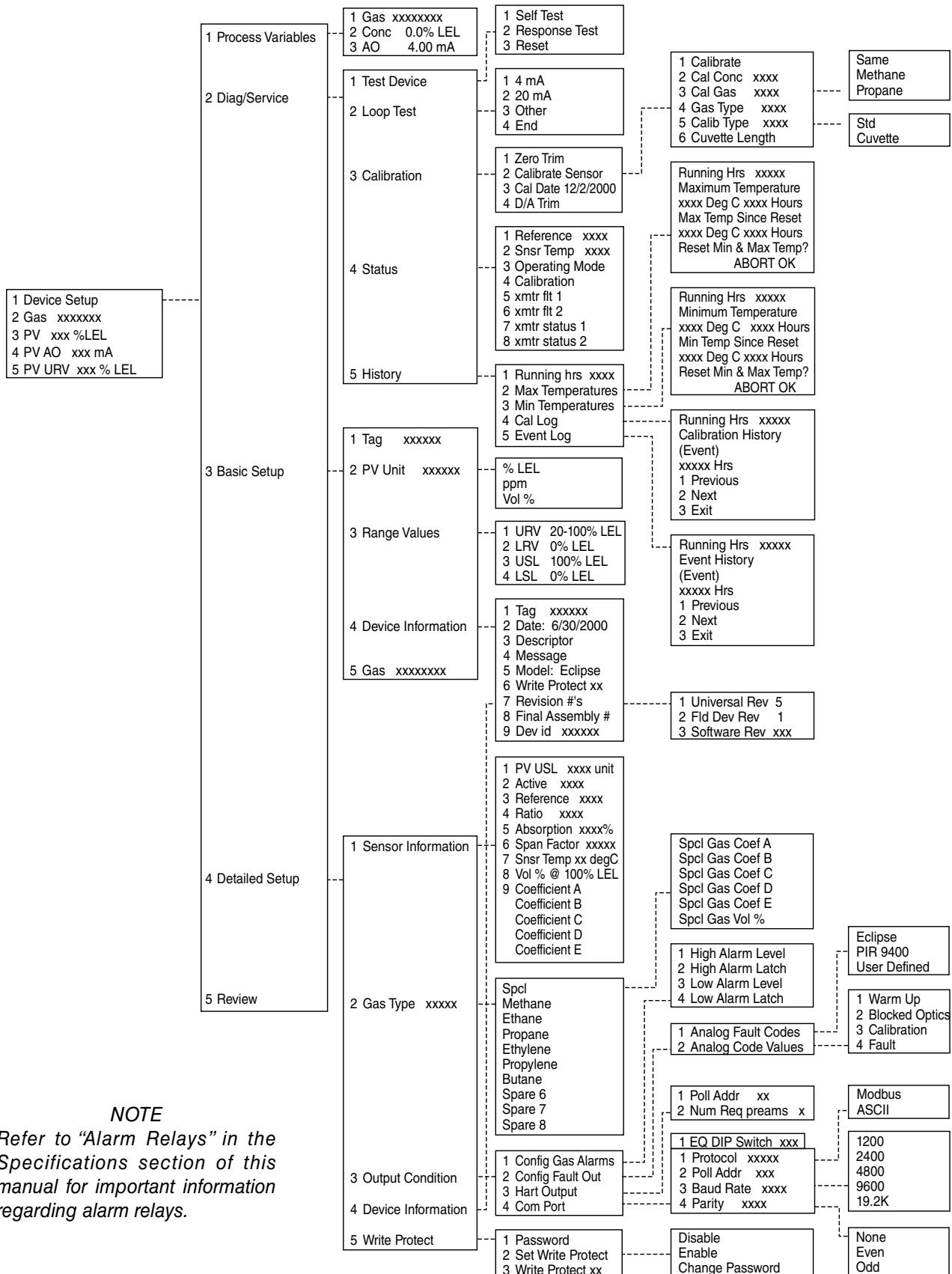

NOTE

Refer to "Alarm Relays" in the Specifications section of this manual for important information regarding alarm relays.

CONNECTIONS AND HARDWARE

The HART Communicator can interface with the Eclipse from the onboard I.S. communication port, from the control room, or any wiring termination point in the analog output signal loop. To communicate, connect the HART communicator in parallel with the Eclipse analog signal or load resistor. The connections are non-polarized.

NOTE

The HART Communicator needs a minimum of 250 ohms resistance in the loop to function properly. The HART Communicator does not measure loop resistance. Any external ohmmeter is required.

COMMONLY USED HART COMMANDS

The most commonly used HART commands for the PIRECL are:

1. Performing basic setup functions such as:
 - Assigning a tag number to the detector
 - Assigning unit of measure (%LEL, PPM, % Vol)
2. Performing detailed setup functions such as:
 - Assigning a special gas type
 - Configuring Gas Alarm Levels (Low & High threshold)
 - Configuring Fault Codes (analog signal output levels during various fault conditions)
 - Configuration of HART and MODBUS communication protocols
 - Write-protecting the HART programming, or assigning a password to protect the setup.
3. Performing Diagnostic and Service functions such as:
 - Reset Alarms or Faults
 - Performing a signal loop output test
 - Performing a Calibration
 - Monitoring detector history/data logs

It is important for the user to understand how to correctly operate the HART Field Communicator, and how to navigate through the various programming options and either select or de-select the desired parameters. This document does NOT cover this fundamental information on the HART Field Communicator. Please refer to the Field Communicator instruction manual for specific guidance on how to operate the communicator.

TYPICAL SETUP OF A PIRECL

After HART communication has been established with the PIRECL, the following operational parameters are generally verified:

1. Inspect the Root menu to confirm that the gas type selected is proper for the gas hazard to be detected. Methane gas is the factory default gas type. If methane is not the desired gas type, then change the setting using the detailed setup programming option, and perform a field calibration using the same gas type as is selected. Refer to the Calibration section of this manual.
2. Inspect the Gas Alarm level thresholds and Fault output signals using the Detailed setup option, and modify these settings if required.
3. Enter a device Tag number and/or descriptor for future traceability and guidance.

While these three operations are typical, these steps may not be satisfactory for your application.

The following data provides basic guidance on HART menu navigation. Refer to the HART Field Communicator manual for additional guidance.

ONLINE MENU

When HART communication is established with the PIRECL, the first menu displayed is the Root menu:

To select any of the 5 menu options shown, highlight the desired option using the up/down arrow key, and then press the "right arrow" key.

1 Device Setup
2 Gas xxxxx
3 PV xxx %LEL
4 PV AO xxx mA
5 PV URV xxx %LEL

1 Device Setup

Press to access the Device Setup menu from the Online menu. The Device Setup menu accesses every configurable parameter of the connected device. Refer to the Device Setup SubMenu for more information.

2 Gas

This shows gas type selected for detection. Factory default setting is methane.

3 PV (Primary Variable)

This shows the gas concentration being detected in %LEL.

4 PV AO (Analog Output)

This shows the Analog output level in selected units, typically milliamperes.

5 PV URV (Upper Range Value)

Select URV to view the upper range value and related engineering units.

DEVICE SETUP SUBMENU

The Device Setup menu accesses every configurable parameter of the connected device. The first accessible setup parameters include:

1 Process Variables

Selecting this menu item will list all process variables and their values.

These process variables are continuously updated, and include:

Gas xxxxx (gas type being detected).

Conc 0.0 % (concentration of gas in % full scale).

AO 4.00 mA (analog output of device).

2 Diag/Service Menu

Selecting this menu offers device and loop tests, calibration, and status/history options.

Refer to the Diag/Service Submenu for more information.

3 Basic Setup

This menu provides quick access to a number of configurable parameters including tag, unit, range values, device information, and gas type. Refer to the Basic Setup Submenu for additional information.

The options available in the Basic Setup menu are the most fundamental tasks that can be performed with a given device. These tasks are a subset of the options available under the Detailed Setup menu.

4 Detailed Setup

Press to access the Detailed setup menu.

This menu provides access to:

- 1 Sensor information
- 2 Gas Type
- 3 Output Condition
- 4 Device information
- 5 Write protect

Refer to the Detailed Setup Submenu for additional information.

5 Review

Press to access the Review menu. This menu lists all of the parameters stored in the connected device, including information about the measuring element, signal condition, and output. It also includes stored information about the connected device such as tag, materials of construction, and device software revision.

- | |
|---------------------|
| 1 Process Variables |
| 2 Diag/Service |
| 3 Basic Setup |
| 4 Detailed Setup |
| 5 Review |

DIAGNOSTICS/SERVICE MENU

The specific diagnostic and/or service functions available are:

1 Test Device

- 1 Self-test. Internal tests are performed and any problems are reported in xmtr flt 1 and xmtr flt 2.
- 2 Response Test. The analog output is held at 4 mA to prevent the alarm relays from activating when gas is applied. Gas response is indicated by the PV.
- 3 Reset. Latched relay outputs are reset.

2 Loop Test

This test allows the operator to manually set the analog signal output to a selected constant value.

3 Calibration

This menu option initiates the calibration routine and is used to set device calibration preferences.

Calibration Submenus include:

- 1 Zero Trim. The current sensor input is used as the new zero reference.
- 2 Calibrate Sensor. This is the command used to calibrate the Eclipse Detector. Submenus include:
 - 1 Calibrate. Zero and span calibrations are performed.
 - 2 Cal Concentration. The output will be set to this value when gas is applied during calibration.
 - 3 Cal Gas
 - 4 Gas Type. Submenu includes optional gases:
 - Methane
 - Propane
 - 5 Calibration Type. Submenu includes options:
 - Standard
 - Cuvette
 - 6 Cuvette Length (in millimeters)
- 3 Calibration Date (CalDate). Shows date of last calibration
- 4 D/A trim (internal use only).

4 Status

This menu option shows extensive status information about the detector. Data available includes:

- 1 Reference xxxx (output value of the reference sensor).
- 2 Snr temp xxxx (temperature of the sensor that is making the process measurement).
- 3 Operating mode (calibration, normal, reset)
- 4 Calibration
- 5 xmtr flt 1. Xmtr flt and xmtr status provide status information relating to failures, warnings and status of processes.
- 6 xmtr flt 2
- 7 xmtr status 1
- 8 xmtr status 2

1 Test Device

2 Loop Test

3 Calibration

4 Status

5 History

5 History

This menu option shows extensive historical information about the detector. Data available includes:

- 1 Running hrs xxxx (the number of hours the unit has been powered).
- 2 Max temperatures (the maximum temperatures recorded in the device).
See max temperature submenu below.
- 3 Min temperatures (the minimum temperatures recorded in the device).
See min temperature submenu below.
- 4 Cal log (data regarding stored calibrations). The most recent calibration is shown first.
Calibrations are recorded as zero only cal, cal OK (zero and span were successfully completed), and cal failed. See cal log submenu below.
- 5 Event log (data regarding stored events). The most recent event is shown first.
Recorded events include blocked optics, warm-up, zero drift, low alarms and high alarms.
See event log submenu below.

Max Temperature Submenu:

Running hrs xxxx
Maximum Temperature
xxxx degC xxxx hours
Max temp since reset
xxxx degC xxxx hours
Reset min&max temp?
ABORT OK

Min Temperature Submenu:

Running hrs xxxx
Minimum Temperature
xxxx degC xxxx hours
Min temp since reset
xxxx degC xxxx hours
Reset min&max temp?
ABORT OK

Cal Log Submenu:

Running hrs xxxx
Calibration history
(Event)
xxxxx Hrs
1 Previous
2 Next
3 Exit

Event Log Submenu:

Running hrs xxxx
Event history
(Event)
xxxx Hrs
1 Previous
2 Next
3 Exit

BASIC SETUP SUBMENU

The tag number identifies a specific device. Changing units affects the engineering units that are displayed. Re-ranging changes the analog output scaling.

1 Tag

Press to access the Tag number menu. Enter the device tag number as desired.

2 PV Unit

Press to access PV Unit submenu. Select %LEL for standard combustible applications.

- % LEL
- ppm
- Vol %

3 Range Values

Press to access Range Values submenu.

- 1 URV 60% LEL (upper range value).
- 2 LRV 5.0% LEL (lower range value).
- 3 USL 60% LEL (upper sensor limit).
- 4 LSL 5.0% LEL (lower sensor limit).

4 Device Information

Press to access device information submenu:

- 1 Tag xxxx
- 2 Date 6/30/2000
- 3 Descriptor (text associated with the field device that can be used by the operator in any way).
- 4 Message (text associated with the field device that can be used by the operator in any way).
- 5 Model: Eclipse
- 6 Write protect xx. This indicates whether variables can be written to the device, or whether commands that cause actions to be performed in the device can or cannot occur.
- 7 Revision #'s. See Revision #'s submenu below.
- 8 Final assembly num
- 9 Dev id xxxx (a number is used to identify a unique field device).

Revision # submenu

offers selection options for:

- 1 Universal rev
- 2 Fld dev rev
- 3 Software rev xx

5 Gas

Type of gas being detected.

1 Tag
2 PV Unit xxxxx
3 Range Values
4 Device Information
5 Gas xxxxxx

DETAILED SETUP MENU

1 Sensor Information

This menu provides detailed information on the internal detector operations. Submenu options include:

- 1 PV USL xxxx. The upper sensor limit value defines the maximum usable value for the upper range of the sensor.
- 2 Active xxxx (output value of the active sensor).
- 3 Reference xxxx (output value of the reference sensor).
- 4 Ratio xxxx (the ratio of the active sensor over the reference sensor).
- 5 Absorption xxxx % (the gas absorption expressed in percent).
- 6 Span Factor xxxx (the number used in calibrating this specific device).
- 7 Snsr temp xx degC (the temperature of the sensor that is making the process measurement).
- 8 Vol % @ 100%LEL (the % volume of gas equal to 100% LEL).
- 9 Coefficient A
Coefficient B
Coefficient C
Coefficient D
Coefficient E

2 Gas Type

Select the gas to be detected here. Submenu options include:

- Spcl
 - Spcl Gas Coef A
 - Spcl Gas Coef B
 - Spcl Gas Coef C
 - Spcl Gas Coef D
 - Spcl Gas Coef E
 - Spcl Gas Vol %
- Methane
- Ethane
- Propane
- Ethylene
- Propylene
- Butane
- Spare 6
- Spare 7
- Spare 8

- | |
|----------------------|
| 1 Sensor Information |
| 2 Gas Type xxxxx |
| 3 Output Condition |
| 4 Device Information |
| 5 Write Protect |

3 Output Condition

Select and configure the output signal options for the Eclipse detector. Submenu options:

1 Config Gas Alarms. Submenu options include:

- 1 High Alarm Level. The high alarm level cannot be set higher than 60% LEL or lower than the low alarm level.
- 2 High Alarm Latch
- 3 Low Alarm Level. The low alarm level cannot be set lower than 5% LEL or higher than the high alarm level.
- 4 Low Alarm Latch

NOTE

Refer to "Alarm Relays" in the Specifications section of this manual for important information regarding alarm relays.

2 Config fault out. Submenu options include:

1 Analog fault codes. This programs the analog output used to indicate faults. Submenu options include:

- Eclipse
- PIR 9400
- User defined

2 Analog code values. Submenu options include:

- 1 Warm up
- 2 Blocked Optics
- 3 Calibration
- 4 Fault

3 Hart output. Submenu options include:

- 1 Poll addr xx (address used by the host to identify a field device).
- 2 Num req preams x (Number of Request Preambles).

4 Com Port. Submenu options include:

1 EQ DIP switch xxx (used with Eagle Quantum systems only).

1 Protocol xxxx (protocol for RS-485 communications). Submenu options:

- Modbus
- ASCII

2 Poll addr xxx (polling address for RS-485 communications).

3 Baud Rate xxxx (baud rate for RS-485 communications). Submenu options include:

- 1200
- 2400
- 4800
- 9600
- 19.2k

4 Parity xxxx (parity for RS-485 communications). Submenu options include:

- None
- Even
- Odd

4 Device Information

Press to access device information submenu:

- 1 Tag xxxx
- 2 Date 6/30/2000
- 3 Descriptor (text associated with the field device that can be used by the operator in any way).
- 4 Message (text associated with the field device that can be used by the operator in any way).
- 5 Model: Eclipse
- 6 Write protect xx. This indicates whether variables can be written to the device, or whether commands that cause actions to be performed in the device can or cannot occur.
- 7 Revision #'s. See Revision #'s submenu below.
- 8 Final assembly num
- 9 Dev id xxxx (a number used to identify a unique field device).

Revision # submenu

offers selection options for:

- 1 Universal rev
- 2 Fld dev rev
- 3 Software rev xx

5 Write Protect

Enable/disable password and write protection capability. Submenu options include:

- 1 Password. A password is required to enable writing to the device.
- 2 Set Write Protect
 - Disable
 - Enable
 - Change Password
- 3 Write Protect xx. This indicates whether variables can be written to the field device or whether commands that cause actions to be performed in the device can or cannot occur.

APPENDIX B

MODBUS COMMUNICATION

OVERVIEW

This appendix outlines the communication protocol and related memory structures that define the interface between PointWatch Eclipse Gas Detector and a system MODBUS Master. The system MODBUS Master is defined as any device capable of reading and writing to the holding register area of a MODBUS slave device. This includes proprietary software, HMI systems such as Wonderware and The FIX, PLCs and DCSs.

The Eclipse will respond as a slave device to a MODBUS Master, allowing the master to control data flow. A MODBUS memory map is defined, which divides memory into functional blocks consisting of: factory constants, configuration information, real time status, control and device defined information. Each block is then subdivided into individual variables that may be simple integers or floating point numbers.

WIRING

Typical RS-485/Modbus communication architecture is indicated in the diagram below. Eclipse units act as slave devices to a Modbus Master. Multiple Eclipse units are daisy-chained for RS-485 communication. If long cable runs are used, 120 Ohm end-of-line termination resistors may be required.

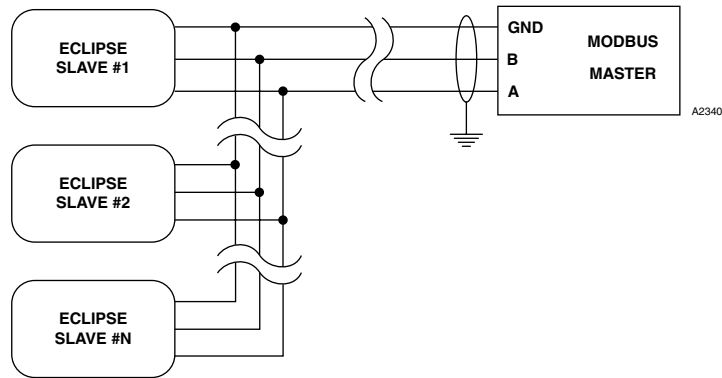

Individual Eclipse units are wired as shown below. Note the inclusion of the end-of-line termination resistor.

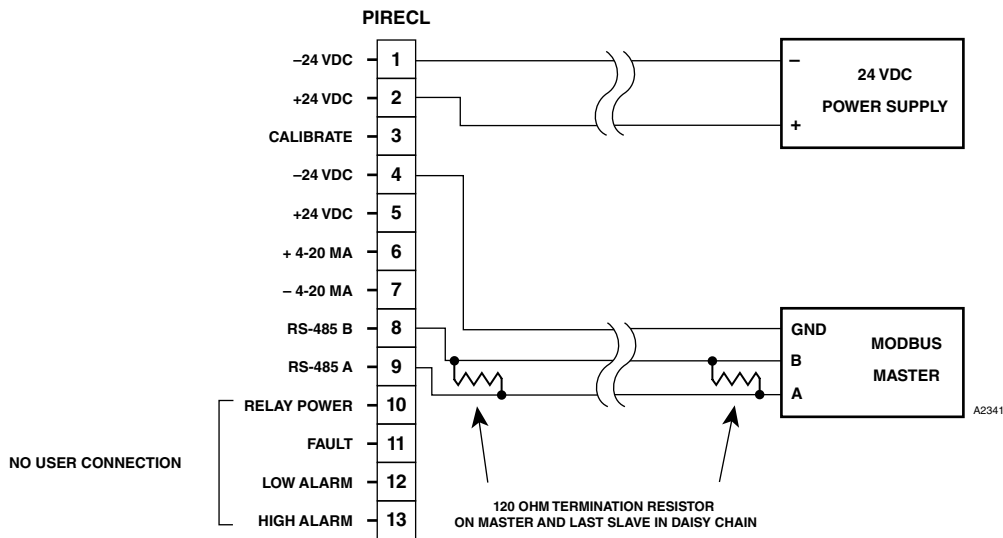

For more information, refer to the EIA RS-485-A standard.

HARDWARE LAYER

RS-485 is used for the hardware interface layer. The output drivers are capable of driving at least 32 devices. The device RS-485 output is tri-stated until a command address matches the programmed address. Default serial settings are MODBUS protocol, address 1, 9600 baud, 1 stop bit, and no parity.

MODBUS FUNCTION CODES

Supported Modbus Functions	
Function Number	Definition
3	Read holding registers
6	Preset single registers
16	Preset multiple registers

MEMORY MAP

Description	Starting Address	Ending Address	Size in Words	Access	Memory Type
Factory Constants	40001	40100	100	Read/Write at Factory	Flash/EEPROM
Device Configuration	40101	40200	100	Read/Write	EEPROM
Status Information	40201	40300	100	Read Only	Ram
Control Words	40301	40400	100	Write Only	Pseudo RAM
Event Logs	40401	40430	30	Read Only	EEPROM
Calibration Logs	40431	40460	30	Read Only	EEPROM
Raw Signal Buffer	40500	40979	480	Read Only	Ram

ECLIPSE MEMORY MAP

Factory Constants

This area holds values determined at the time of manufacture. Device type and firmware version is determined when the program is compiled and can't be changed. The serial number and manufacture date is written as part of the manufacturing process.

Eclipse Factory Constants		
Description	Address	Value
Device Type	40001	3 (Eclipse)
Firmware Version	40003	00.00..99.99
Serial Number	40004	Unsigned Long LSW
	40005	Unsigned Long MSW
Year (Manufacture Date)	40006	1999
Month	40007	1..12
Day	40008	1..31
Reserved	40009 to 40010	

Device Configuration: (Read/Write)

This area of memory holds field adjustable parameters for the device. The Hart configuration changed bit will be set on writes to this area.

Eclipse Device Configuration		
Description	Address	Value
Modbus Polling Address	40101	1..247
Baud Rate Code	40102	See Codes
Parity Code	40103	See Codes
Gas Type	40104	See Codes
Calibration Gas Type	40105	See Codes
Calibration Method	40106	See Codes
Calibration Cuvette Length (1.0 to 150.0 mm)	40107	Float LSW
	40108	Float MSW
Analog Fault Code	40109	See Codes
4 to 20 Range (20 to 100% LEL)	40110	Float LSW
	40111	Float MSW
Cal Gas Concentration (20 to 100% LEL)	40112	Float LSW
	40113	Float MSW
Warmup Fault Level (0.0 to 24.0 mA)	40114	Float LSW
	40115	Float MSW
Blocked Optics Fault Level (0.0 to 24.0 mA)	40116	Float LSW
	40117	Float MSW
Calibration Current Level (0.0 to 24.0 mA)	40118	Float LSW
	40119	Float MSW
General Fault Current Level (0.0 to 24.0 mA)	40120	Float LSW
	40121	Float MSW
Volume at LEL (Special Gas Type)	40122	Float LSW
	40123	Float MSW
Gas Coefficient a (Special Gas Type)	40124	Float LSW
	40125	Float MSW
Gas Coefficient b (Special Gas Type)	40126	Float LSW
	40127	Float MSW
Gas Coefficient c (Special Gas Type)	40128	Float LSW
	40129	Float MSW
Gas Coefficient d (Special Gas Type)	40130	Float LSW
	40131	Float MSW
Gas Coefficient e (Special Gas Type)	40132	Float LSW
	40133	Float MSW
Low Alarm Level (5 to 60% LEL)	40134	Float LSW
	40135	Float MSW
High Alarm Level (5 to 60% LEL)	40136	Float LSW
	40137	Float MSW
Low Alarm Latch	40138	See Codes
High Alarm Latch	40139	See Codes
Reserved	40140	

NOTE
Refer to "Alarm Relays" in the Specifications section of this manual for important information regarding alarm relays.

Device Status (Read only)

This area of memory holds real time status information.

Eclipse Status Information		
Description	Address	Value
General Status Bits	40201	Bit Values (See below)
Fault Status Bits	40202	Bit Values (See below)
Gas Level in LEL	40203	Float LSW
	40204	Float MSW
Calibration Step	40205	See Codes
Active Sensor Signal	40206	Float LSW
	40207	Float MSW
Reference Sensor Signal	40208	Float LSW
	40209	Float MSW
Sensor Ratio	40210	Float LSW
	40211	Float MSW
Sensor Absorption	40212	Float LSW
	40213	Float MSW
Temperature (°C)	40214	Float LSW
	40215	Float MSW
Hour Meter	40216	Unsigned Long LSW
	40217	Unsigned Long MSW
Max Temperature	40218	Float LSW
	40219	Float MSW
Max Temp Hour	40220	Unsigned Long LSW
	40221	Unsigned Long MSW
Max Temp (Since Reset)	40222	Float LSW
	40223	Float MSW
Max Temp Hour (Since Reset)	40224	Unsigned Long LSW
	40225	Unsigned Long MSW
Ram Error Code	40226	Unsigned Integer
Volume at LEL (Current Gas Type)	40227	Float LSW
	40228	Float MSW
Gas Coefficient a (Current Gas Type)	40229	Float LSW
	40230	Float MSW
Gas Coefficient b (Current Gas Type)	40231	Float LSW
	40232	Float MSW
Gas Coefficient c (Current Gas Type)	40233	Float LSW
	40234	Float MSW
Gas Coefficient d (Current Gas Type)	40235	Float LSW
	40236	Float MSW
Gas Coefficient e (Current Gas Type)	40237	Float LSW
	40238	Float MSW

Eclipse Status Information (continued)		
Description	Address	Value
Min Temperature	40239	Float LSW
	40240	Float MSW
Min Temp Hour	40241	Unsigned Long LSW
	40242	Unsigned Long MSW
Min Temp (Since Reset)	40243	Float LSW
	40244	Float MSW
Min Temp Hour (Since Reset)	40245	Unsigned Long LSW
	40246	Unsigned Long MSW
Fixed 4 to 20 mA Value	40247	Float LSW
	40248	Float MSW
Reserved	40249	
Reserved	40250	
Reserved	40251	
Reserved	40252	
Zero Ratio	40253	Float LSW
	40254	Float MSW
Span Factor	40255	Float LSW
	40256	Float MSW
5 Volt Power Supply Value (As read by ADC)	40257	Float LSW
	40258	Float MSW
12 Volt Power Supply Value (As read by ADC)	40259	Float LSW
	40260	Float MSW
24 Volt Power Supply Value (As read by ADC)	40261	Float LSW
	40262	Float MSW

General Status Bits

These bits are used to signal the current operating mode of the device.

Name	Bit	Description
Device Fault (any fault)	0	Set for all fault conditions
Calibration Active	1	Set during calibration
Warm up Mode	2	Set during warm-up
Low Alarm Active	3	Set while alarm is active
High Alarm Active	4	Set while alarm is active
Output Current Fixed	5	Set when output current is fixed
Modbus Write Protect	6	0 = Locked 1 = Unlocked
Calibration Input Active	7	True while the cal line is active
Magnetic Switch Active	8	True while the onboard magnetic switch is active
Hart Initiated Self Test	9	True when self test is initiated from the Hart interface
Reserved	10	
Response Test Active	11	True during the gas response test.
Manual Self Test Active	12	True during manual self test

Fault Status Word

These bits are used to signal the active faults of the device.

Name	Bit
Calibration Fault	0
Dirty Optics	1
Open Lamp	2
Cal Active at start	3
EE Error 1	4
EE Error 2	5
Ref ADC Saturated	6
Active ADC Saturated	7
Bad 24 volts	8
Bad 12 volts	9
Bad 5 volts	10
Zero Drift	11
Flash CRC Error	12
Ram Error	13

Control Words

Setting values in this area of memory initiates action in the device. For example, it may start a calibration sequence. The device automatically clears command word bits after the function is performed.

Eclipse Control Words		
Description	Address	Value
Command Word 1	40301	See below
Command Word 2 (Reserved)	40302	
Reserved	40303 to 40306	

Command Word 1

Description	Bit
Start Calibration	0
Abort Calibration	1
Warm up Mode	2
Low Alarm Active	3
High Alarm Active	4
Output Current Fixed	5
Modbus Write Protect	6
Calibration Input Active	7
Magnetic Switch Active	8
Hart Initiated Self Test	9
Reserved	10
Response Test Active	11
Manual Self Test Active	12
End Response Test	13
Reserved	14
Start Manual Self Test	15

Event Logs

Fault and calibration logs are held in this area of memory.

Eclipse Event Logs			
Description	Address	Value	Notes
Event Hour	40401	Unsigned Long LSW	1 of 10 logs
	40402	Unsigned Long MSW	
Event ID 1	40403	See Codes	
Event Hour	40428	Unsigned Long LSW	Last of 10
	40429	Unsigned Long MSW	
Event ID 10	40430	See Codes	
Event Hour	40431	Unsigned Long LSW	1 of 10 logs
	40432	Unsigned Long MSW	
Calibration Event ID 1	40433	See Codes	
Event Hour	40458	Unsigned Long LSW	Last of 10
	40459	Unsigned Long MSW	
Calibration Event ID 10	40460	See Codes	

VALUE CODES

Baud Rate Code

Description	Code
1200	0
2400	1
4800	2
9600 (Default)	3
19200	4

Parity Code

Description	Code
None (Default)	0
Even	1
Odd	2

Gas Type

Description	Code
Methane	0
Ethane	1
Propane	2
Ethylene	3
Propylene	4
Butane	5
Reserved	6
Reserved	7
Reserved	8
Special	9

Calibration Gas Type

Description	Code
Same as Measured	0
Methane	1
Propane	2

Calibration Method

Description	Code
Standard	0
Cuvette	1

Analog Fault Code

Description	Code
Eclipse	0
PIR 9400	1
User Defined	2

Calibration Step

Description	Code
Waiting to Start	0
Waiting for Zero	1
Waiting for Signal	2
Waiting for Gas	3
Waiting for Span	4
Waiting for End	5
Calibration Terminated	6
Calibration Complete	7

Alarm Latch Configuration

NOTE

Refer to "Alarm Relays" in the Specifications section of this manual for important information regarding alarm relays.

Description	Code
Non-Latching	0
Latching	1

Event Log ID Codes

Description	Code
Empty	0
Blocked Beam	1
Warm-up	2
Zero Drift	3
Low Alarm	4
High Alarm	5

Calibration Log ID Codes

Description	Code
Empty	0
Zero Cal	1
Zero and Span	2
Failed Cal	3

ASCII PROTOCOL

The RS485 serial port can be configured for ASCII protocol, which is intended for applications that don't require custom software on the host side. Off the shelf terminal emulation software can be used to receive messages from the device. Percent LEL and sensor readings are sent once per second and user prompt messages are sent during the calibration process to guide the user at each step. Default serial settings are 9600 baud, 1 stop bit, and no parity. Protocol and serial parameters should be selected with the HART handheld communicator.

APPENDIX C

EAGLE QUANTUM PREMIER COMPATIBLE ECLIPSE

INSTALLATION AND WIRING

The Eagle Quantum Premier (EQP) version of the Model PIRECL PointWatch Eclipse uses the identical installation procedure, device location guidelines, and power supply requirements as described in the “Installation” section of this manual. Refer to the EQP version wiring diagram for specific wiring termination guidance.

An important difference in EQP applications is that LON network cabling will be routed both in and out from the the EQP Eclipse enclosure, so this requirement should be anticipated and planned for during EQP Eclipse installation.

Table C-1—LON Maximum Cable Lengths

LON Cable (Manufacturer and Part No.)*	Maximum Length**	
	Feet	Meters
Belden 8719	6,500	2,000
Belden 8471	6,500	2,000
FSI 0050-000006-00-NPLFP	6,500	2,000
Technor BFOU	4,900	1,500
Level IV, 22 AWG	4,500	1,370

Note: *Use the same type of cable in each wiring segment between network extenders.

**Maximum wire lengths represent the linear wire distance of LON communications wiring between network extenders.

The maximum wire lengths given in Table C-1 are based upon the cable's physical and electrical characteristics.

IMPORTANT

Det-Tronics recommends the use of shielded cable (required by ATEX) to prevent external electromagnetic interference from affecting field devices.

IMPORTANT

For best fault isolation performance, the maximum LON wiring length should not exceed 1600 feet (500 meters).

IMPORTANT

Be sure that selected cable meets all job specifications. The use of other cable types can degrade system operation. If necessary, consult factory for further suggested cable types.

CONFIGURATION AND OPERATION

Configuration of the EQP Eclipse is accomplished using Det-Tronics Safety System Software (S3) that is running on the EQP Operator Interface Station (OIS).

ONBOARD HART PORT

The on-board HART port is functional on the EQP Eclipse, however, it should **not** be used for device configuration purposes. All EQP device configuration should be performed using the S3 program.

MULTI-COLORED LED

Operation of the status indicating LED is identical to all other PIRECL versions.

REMOTE CALIBRATION OPTION

Operation of the remote calibration option is identical to all other PIRECL versions.

ANALOG OUTPUT

A 4-20 mA analog current output is not available with EQP PIRECL.

RS-485 COMMUNICATION

RS-485 communication is not available with EQP PIRECL.

CALIBRATION ROUTINE

The calibration procedure for the EQP PIRECL (normal and zero calibration) is identical to all other PIRECL versions.

NOTE

For complete information regarding installation, configuration or operation of the Eagle Quantum Premier system, refer to form 95-8533 (Eagle Quantum Premier hardware manual) or form 95-8560 (Safety System Software manual).

ECLIPSE OPERATION WITH EAGLE QUANTUM PREMIER

Table C-2—Typical Update Rate for PIRECL in an EQP System

Field Device	Transmit time to Controller (sec)
PIRECL	
Gas Alarms	Immediate
Gas Level	1
Device Fault	1

Table C-3—PIRECL Fixed Alarm Logic (Thresholds Programmed Using S3 Configuration Software)

Field Device	Fire Alarm	High Gas Alarm	Low Gas Alarm	Trouble	Supervisory
PIRECL (Point IR Eclipse)					
High Alarm		X			
Low Alarm			X		

Table C-4—PIRECL Faults and Fixed Logic System Outputs

Field Device VFD Faults	Trouble LED	Trouble Relay
Calibration Fault	X	X
Dirty Optics	X	X

SETTING NETWORK ADDRESSES

Overview of Network Addresses

Each PIRECL IR gas detector on the EQP LON must be assigned a unique address. Addresses 1 to 4 are reserved for the EQP controller. Valid addresses for field devices including PIRECL gas detectors are from 5 to 250.

IMPORTANT

If the address is set to zero or an address above 250, the system will ignore the switch setting and the device.

The LON address is programmed by setting rocker switches on an 8 switch “DIP Switch” located within the PIRECL housing. The address number is binary encoded with each switch having a specific binary value with switch 1 being the LSB (Least Significant Bit). (See Figure C-1.) The device’s LON address is equal to the added value of all closed rocker switches. All “Open” switches are ignored.

Example: for node No. 5, close rocker switches 1 and 3 (binary values 1 + 4); for node No. 25, close rocker switches 1, 4 and 5 (binary values 1 + 8 + 16).

NOTE

For convenience in setting LON address switches, a “Rocker Switch Table” is included in the EQP System manual (form 95-8533, Appendix D).

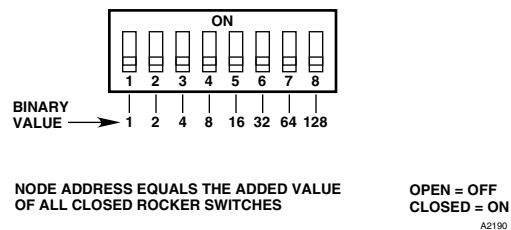

Figure C-1—PIRECL Address Switches

Do not assign duplicated addresses. Duplicated addresses are not automatically detected. Modules given the same address will use the number given and report to the controller using that address. The status word will show the latest update, which could be from any of the reporting modules using that address.

After setting address switches, record the address number and device type on the "Address Identification Chart" (form 95-8487). Post the chart in a convenient location near the Controller for future reference.

IMPORTANT

*The PIRECL sets the LON address only when power is applied to the device. Therefore, it is important to set the switches **before** applying power. If an address is ever changed, system power must be cycled before the new address will take effect.*

PIRECL Address Switches

Address switches for PIRECL are located within the device enclosure. Refer to Figure C-2 for switch location.

WARNING

Disassembly of the PIRECL housing and removal of the front electronics module from the bulkhead is required to gain access to the network address switches. Power should be removed from the detector before disassembly. If disassembly is performed in a hazardous areas, the area must be de-classified before starting disassembly.

WARNING

Disassembly of the PIRECL detector should only be performed with proper electrostatic discharge grounding protection. A controlled lab or shop setting is recommended for device programming.

The PIRECL detector contains semiconductor devices that are sensitive to electrostatic discharge (ESD). Damage caused by electrostatic discharge can be virtually eliminated if the equipment is handled only in a static safeguarded work area and protective measures against static electricity discharge are employed during the disassembly process. Since a static safeguarded work area is usually impractical in most field installations, handle the device by the housing, taking care not to touch electronic components or terminals. Use a wrist grounding strap or similar method at all times to control accidental ESD when disassembling, programming, or reassembling the PIRECL gas detector.

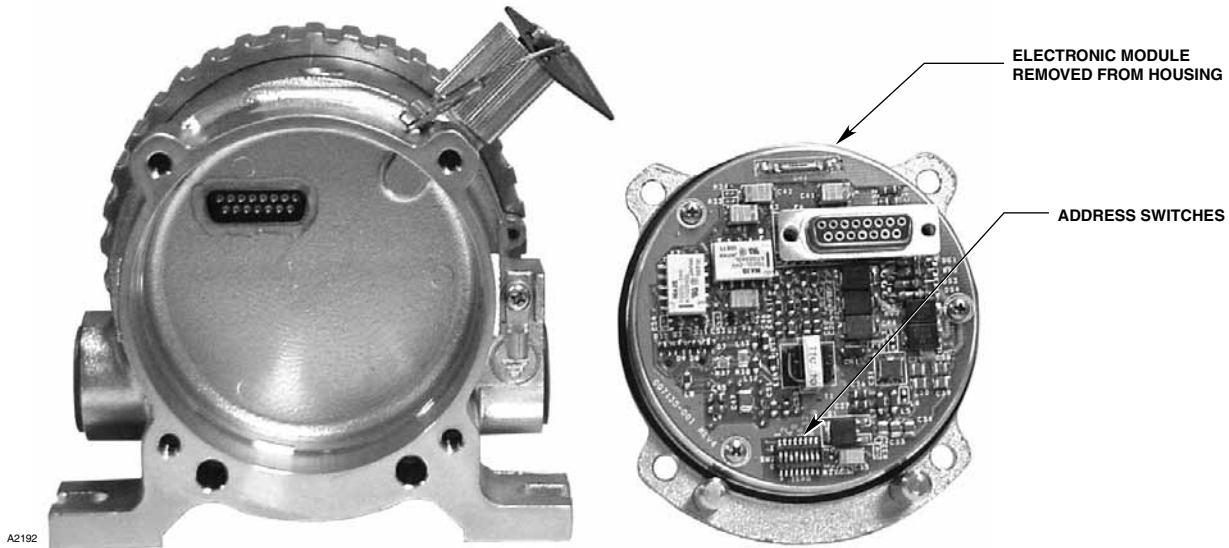

Figure C-2—Location of PIRECL Address Switches

Switch Access Procedure

NOTE

It is strongly recommended to document all PIRECL gas detector network addresses as well as the addresses of all other LON devices on the Address Identification Chart before disassembling and programming the PIRECL gas detectors.

Removal of four stainless steel flange bolts and the front electronic module of the PIRECL IR gas detector from the bulkhead is required in order to gain access to the network address DIP switch. Tools required for this procedure include a 4mm hex wrench and a torque wrench capable of accurately measuring 40 inch-pounds.

1. Remove 24 Vdc power from the PIRECL detector. Remove the weather baffle from the detector.
2. Remove the four stainless steel flange bolts using a 4mm hex wrench. Take care to properly support the electronic module as the last flange bolt is removed.
3. Carefully remove the electronic module by extracting it straight out from the bulkhead.
4. Set the network address switches.
5. Ensure that the module O-ring is intact and undamaged.
6. Reinstall the electronic module by inserting it straight into the bulkhead.

NOTE

Take care to properly align the module's electrical connector with the bulkhead connector before attempting to fully insert the module. Failure to do so may result in damage to the module and/or bulkhead.

7. Insert and tighten the four flange bolts in an opposing consecutive order in two stages — first partially tighten all four bolts equally, and then fully tighten each bolt in an opposing order to 40 inch-pounds (4.5 Nm) of torque. (Bolts are M6 per ISO 965 with M5 head, SST with a yield stress of 448 N/mm² (65,000 PSI) minimum.)
8. Apply power after all network addresses have been programmed and all field enclosures are properly installed.

TYPICAL APPLICATIONS

Figure C-3 is a simplified drawing of a typical EQP system. This system includes an EQP Controller, DCIO and various LON field devices.

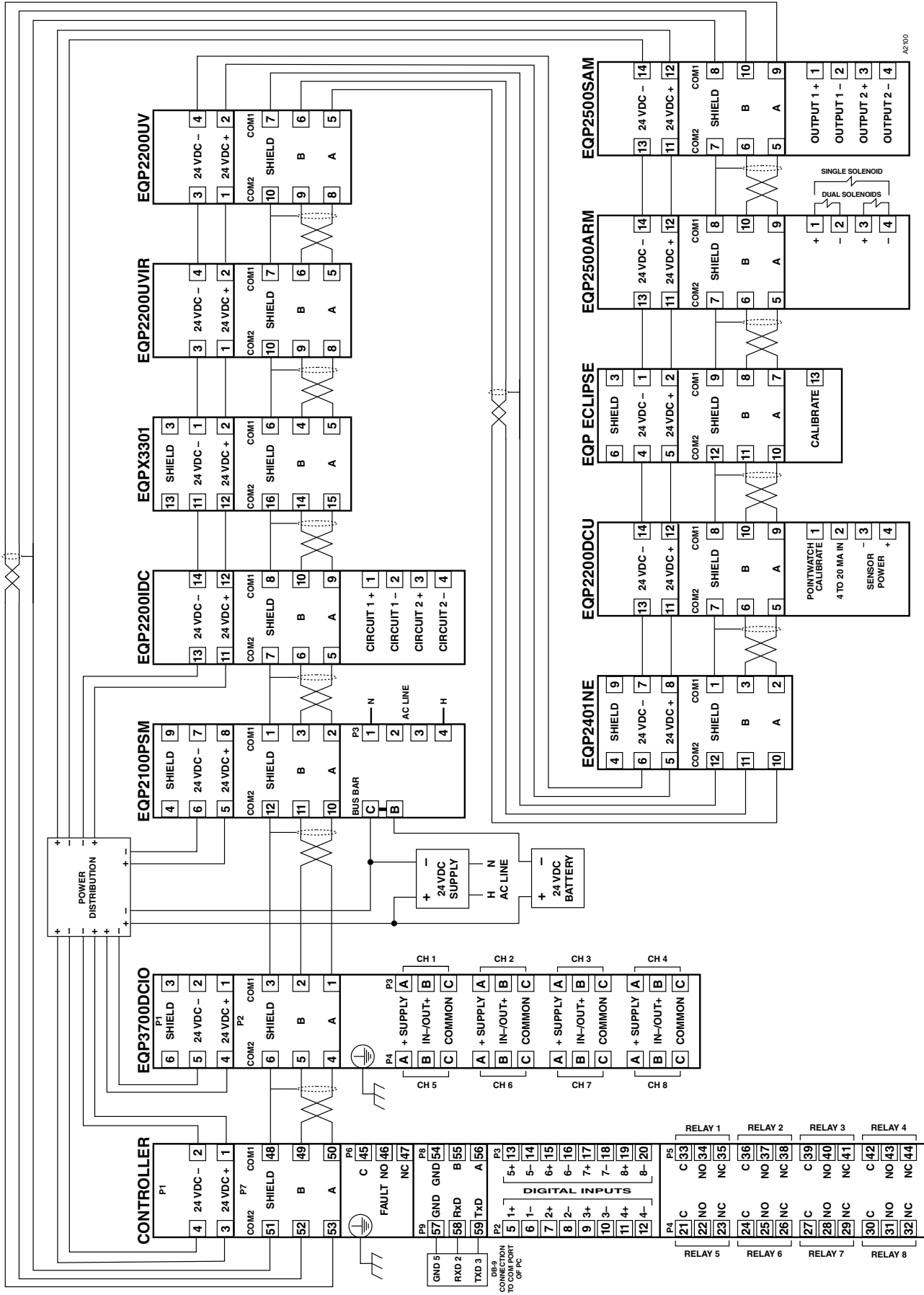

A3100

Figure C-3—A Typical System

APPENDIX D

DETECTION OF OTHER GASES

Pointwatch Eclipse is provided with field-selectable "standard gas" signal processing program settings. These settings are provided for detection and measurement of methane, ethane, propane, ethylene, and propylene gases, and are defined as linearized gas measurement outputs. This means that the Eclipse is capable of providing an analog signal output that is directly proportional to the %LFL concentration for these gases, provided the proper gas setting has been selected, and the Eclipse has been calibrated with the proper calibration gas type. The factory default gas setting is methane gas. The HART Communicator is required to confirm the current setting and change it if required.

In addition to the five standard gases mentioned, the Eclipse is capable of detecting and measuring many other hydrocarbon gases and vapors. Eclipse can be configured to provide a linear output for detection of non-standard gases. For detection of many commonly encountered gases, one of the standard settings will usually suffice. Please consult the factory for details.

Methane Calibrated PointWatch - Response to Standard Gases

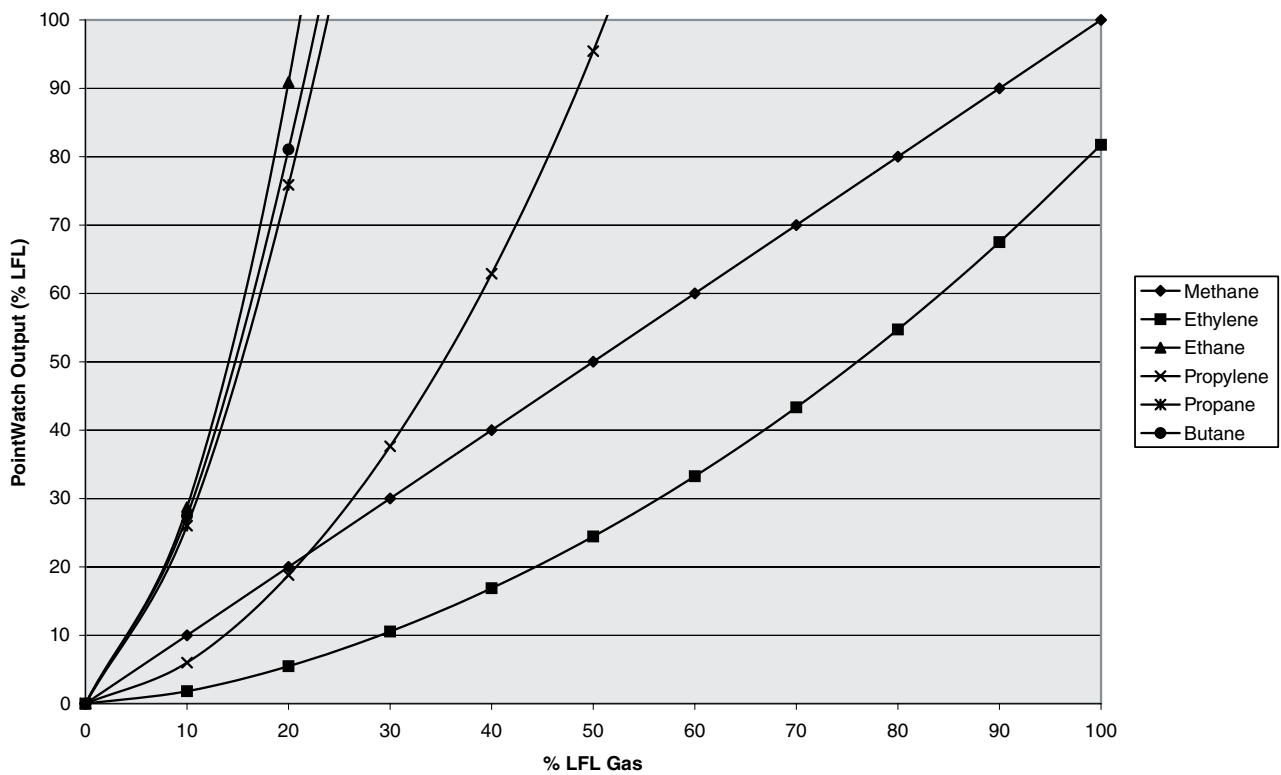

Ethane Calibrated PointWatch - Response to Standard Gases

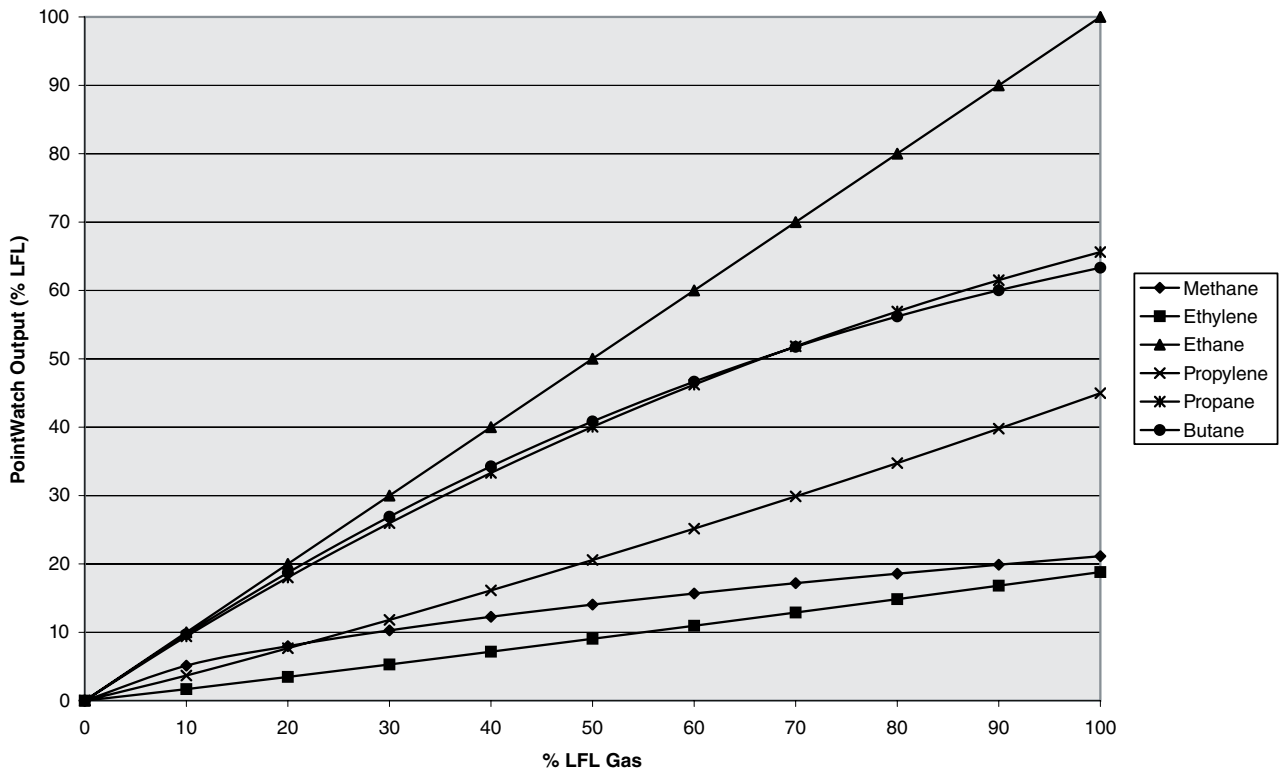

Propane Calibrated PointWatch - Response to Standard Gases

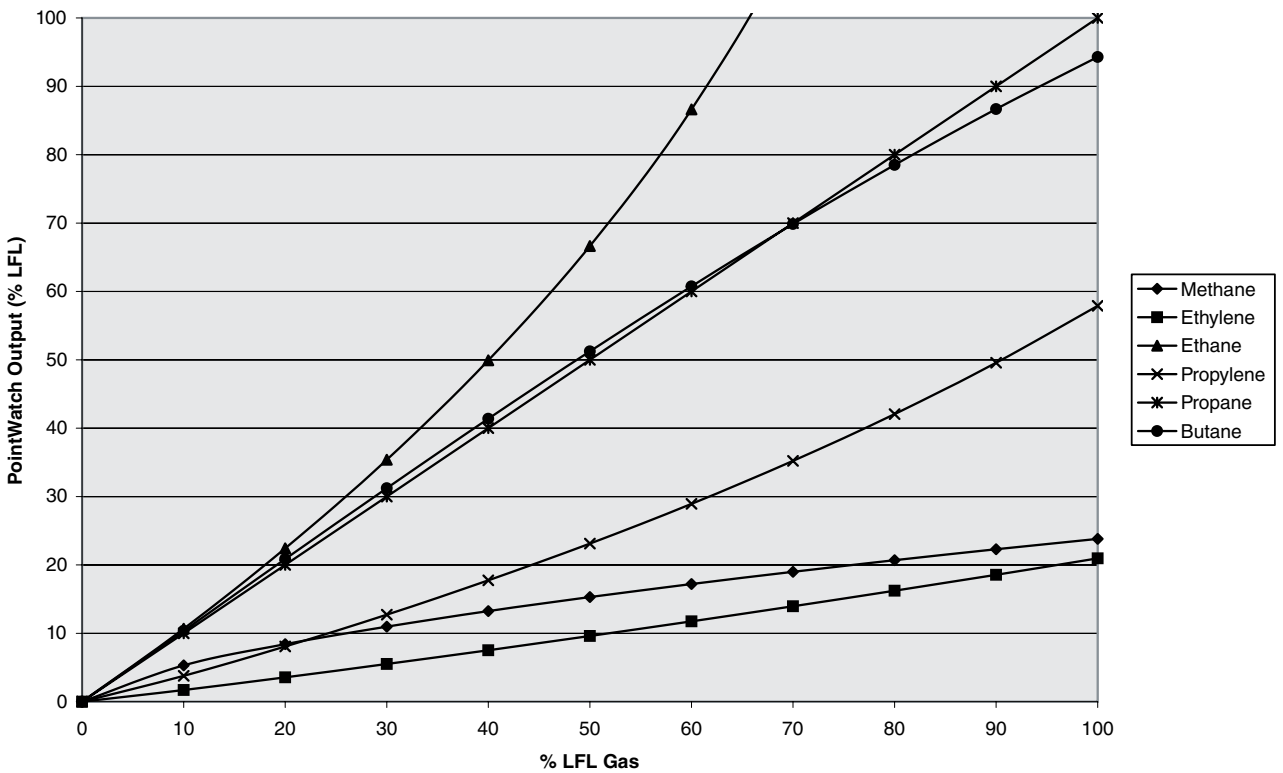

Ethylene Calibrated PointWatch - Response to Standard Gases

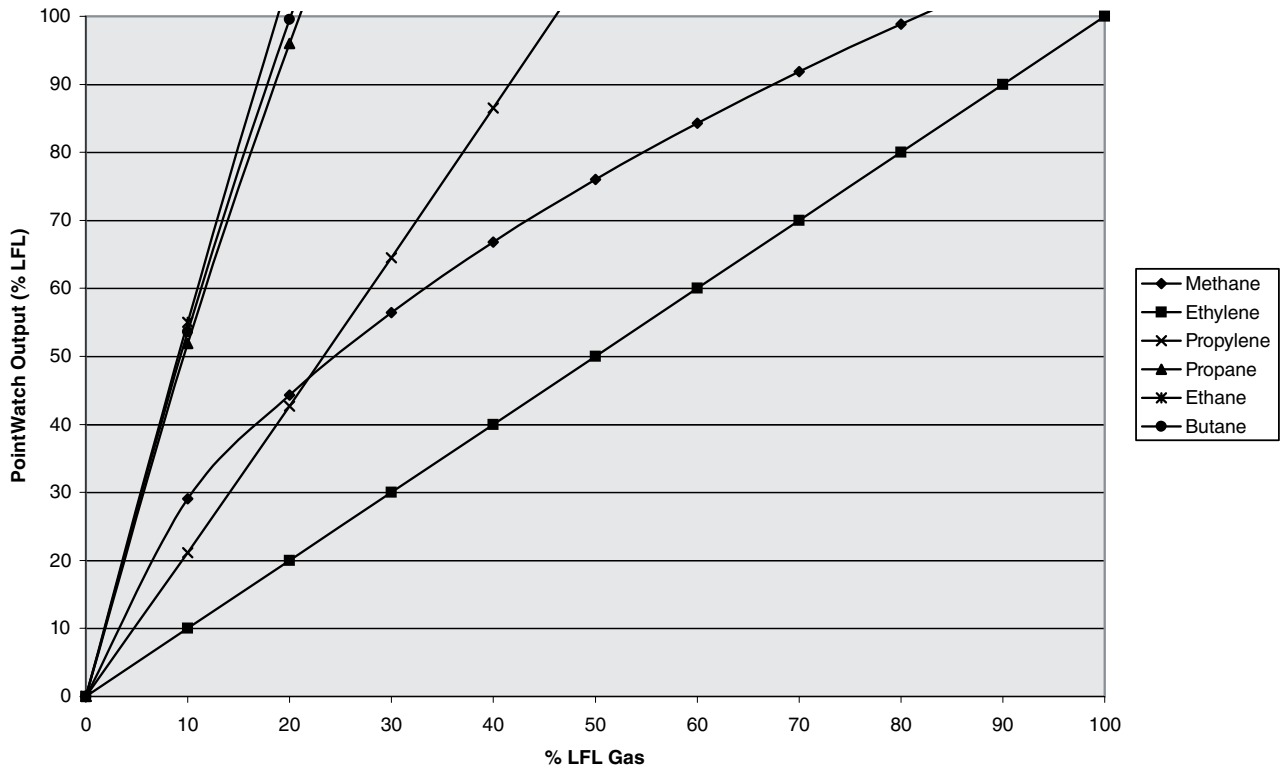

Propylene Calibrated PointWatch - Response to Standard Gases

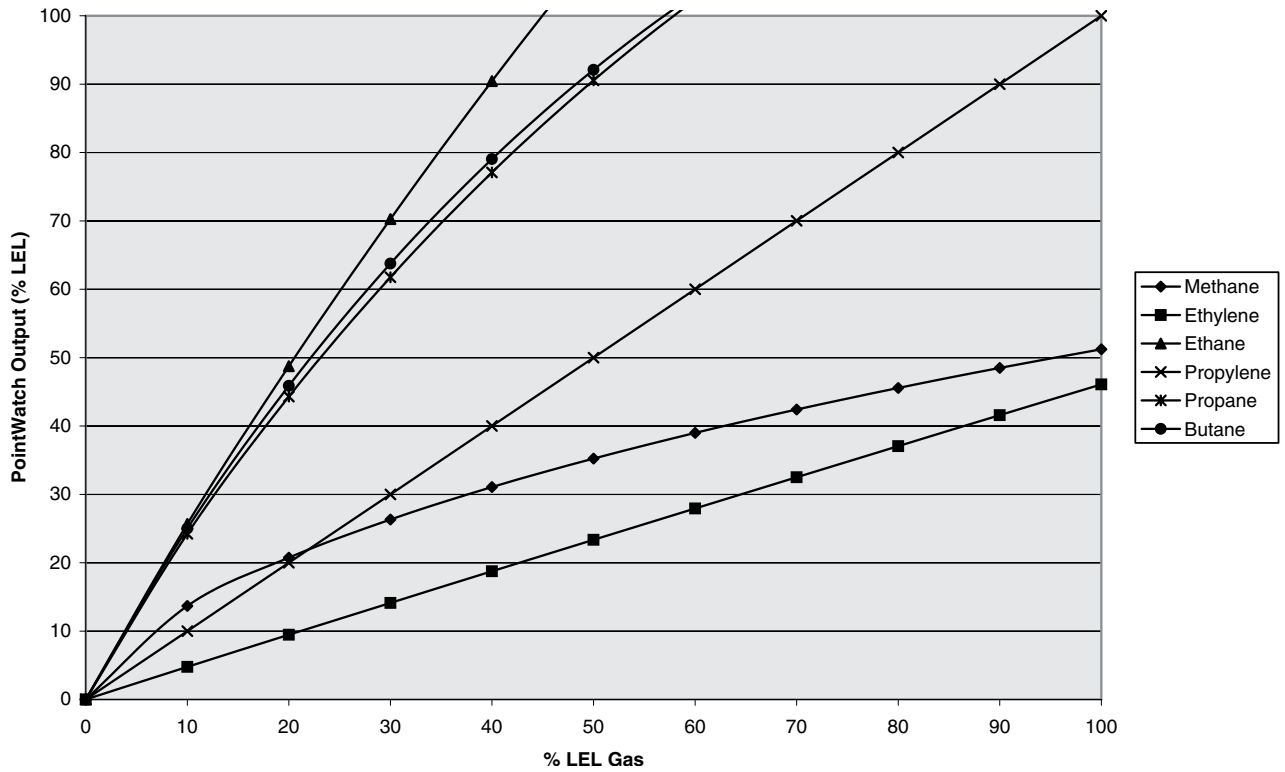

APPENDIX E

WARRANTY

Detector Electronics Corporation products are manufactured from high quality components and the completed device is rigorously inspected and tested before shipment; however, any electronic device is subject to failure beyond the control of the manufacturer. To ensure system reliability, it is important for the user to maintain the system as recommended by the instruction manuals and to determine the frequency of functional checking of the system required for each specific installation. The more frequent the checking, the greater the system reliability. For the highest reliability, a completely redundant system is necessary. The manufacturer warrants the PointWatch Eclipse against defective parts and workmanship, and will replace or repair equipment returned to the manufacturer for these reasons within five years after purchase date. See manufacturer's Standard Terms and Conditions on the invoice for complete details. Please note that no other warranties, written or implied, will be honored by the manufacturer.

CAUTION

The detector contains no user serviceable components. Service or repair should never be attempted by the user. The manufacturer's warranty for this product is void, and all liability for proper function of the detector is irrevocably transferred to the owner or operator in the event that the device is serviced or repaired by personnel not employed or authorized by Detector Electronics Corporation, or if the device is used in a manner not conforming to its intended use.

APPENDIX F

CONTROL DRAWING

THE MODEL PIRECL INFRARED HYDROCARBON GAS DETECTORS PROVIDE AN FM APPROVED AND CSA CERTIFIED INTRINSICALLY SAFE OUTPUT FOR CONNECTION WITH THE HART COMMUNICATOR WHEN INSTALLED PER THE NATIONAL ELECTRICAL CODE (NEC), NFPA 70, ARTICLES 501 & 504 OR CANADIAN ELECTRICAL CODE, C22.1, SECTION 18 & APPENDIX F.

NOTE: TO PREVENT IGNITION OF EXPLOSIVE ATMOSPHERES, READ, UNDERSTAND, AND ADHERE TO THE MANUFACTURERS LIVE MAINTENANCE PROCEDURE.

NON-HAZARDOUS AREA

CLASS I, DIVISION 1, GROUPS B, C, D (T4) WITH INTRINSICALLY SAFE OUTPUT FOR HART COMMUNICATION.

CLASS I, DIVISION 2, GROUPS A, B, C, D (T4)
 {AMBIENT TEMPERATURE LIMITS: -40°C TO +75°C}

INTRINSICALLY SAFE HART PORT: REFERENCE NFPA 70 (NEC), ARTICLE 504. OR C22.1 (CEC), APPENDIX F.	FOR ZONE CLASSIFICATIONS U _o = 4.0V I _o = 100mA C _o = 20µF L _o = 500µH	FOR DIVISION CLASSIFICATIONS U _o = 3.47V I _o = 116.8mA
---	--	--

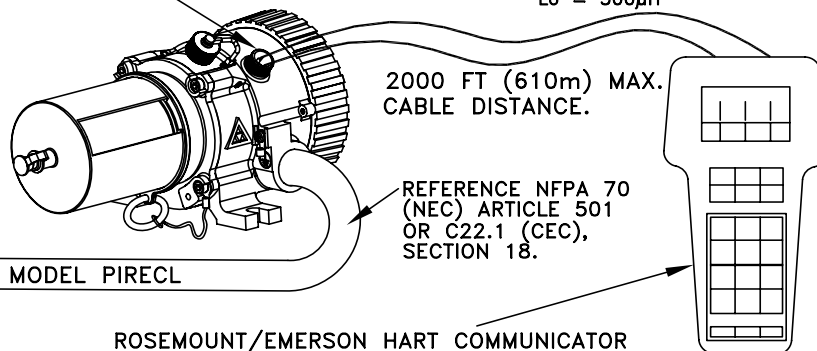
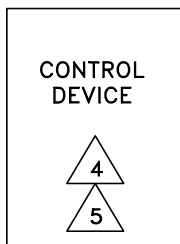

ROSEMOUNT/EMERSON HART COMMUNICATOR
 (NOTE: THIS DRAWING SUPERCEDES ALL ROSEMOUNT/EMERSON HART COMMUNICATOR CONTROL DRAWINGS)

5 IN ORDER TO MAINTAIN SYSTEM APPROVAL, THE CONTROL UNIT CONNECTED TO THE PIRECL(X)4 DETECTOR, SHALL HAVE THE APPROPRIATE THIRD PARTY CERTIFICATION TO PROCESS THE SPECIFIED LON SIGNAL AND PROVIDE THE APPROPRIATE INDICATION.

4 APPROVAL OF THE MODEL PIRECL DOES NOT INCLUDE OR IMPLY APPROVAL OF THE APPARATUS TO WHICH THE DETECTOR MAY BE CONNECTED AND WHICH PROCESSES THE ELECTRONIC SIGNAL FOR EVENTUAL END USE.

3. THE MODEL PIRECL IS CSA CERTIFIED FOR COMBUSTIBLE GAS PERFORMANCE IN ACCORDANCE WITH CSA C22.2 #152.
2. THE MODEL PIRECL IS FM APPROVED FOR COMBUSTIBLE GAS PERFORMANCE IN ACCORDANCE WITH FM 6310/6320 & ANSI/ISA-12.13.01.
1. FM APPROVED/CSA CERTIFIED DRAWING - NO MODIFICATIONS PERMITTED WITHOUT REFERENCE TO APPROVAL AGENCY.

UNLESS OTHERWISE SPECIFIED TOLERANCES ARE:

DIMENSION	TOLERANCE
INCH (MM)	INCH (MM)
0.0 (0)	±.02 ±(0.5)
0.00 (0.0)	±.01 ±(0.25)
0.000 (0.00)	±.005 ±(0.13)

ANGLE ±1°
 REMOVE ALL BURRS BREAK ALL EDGES AND SHARP CORNERS

DET-TRONICS[®]
 DETECTOR ELECTRONICS CORP.
 MINNEAPOLIS, MINNESOTA 55438

THIS DRAWING AND SPECIFICATION CONTAIN PROPRIETARY INFORMATION AND ANY REPRODUCTION DISCLOSURE OR USE THEREOF IS EXPRESSLY PROHIBITED WITHOUT THE WRITTEN PERMISSION OF DETECTOR ELECTRONICS CORPORATION.

SHEET	1 OF 1	DO NOT SCALE DRAWING	SCALE	NONE	SIZE	DRAWING NO.	REV
TITLE	CONTROL DRAWING PIRECL, FM/CSA			A	007283-001	J	



95-8526



X3301 Multispectrum
IR Flame Detector



PointWatch Eclipse®
IR Combustible Gas Detector



FlexVu® Universal Display
w/ GT3000 Toxic Gas Detector



Eagle Quantum Premier®
Safety System

Detector Electronics Corporation
6901 West 110th Street
Minneapolis, MN 55438 USA

T: 952.941.5665 or 800.765.3473

F: 952.829.8750

W: <http://www.det-tronics.com>

E: det-tronics@det-tronics.com



A UTC Fire & Security Company

Det-Tronics, the DET-TRONICS logo, Eagle Quantum Premier, FlexVu and Eclipse are registered trademarks or trademarks of Detector Electronics Corporation in the United States, other countries, or both. Other company, product, or service names may be trademarks or service marks of others.

© Copyright Detector Electronics Corporation 2011. All rights reserved.